

03/2026

VMA VERLAG
Cologne /Germany



EXTRUSION INTERNATIONAL

USA

The new PiXARGUS
ProfilControl 7 XLine
Slim. Flexible.
Affordable.

**IN
SPECT
MORE**

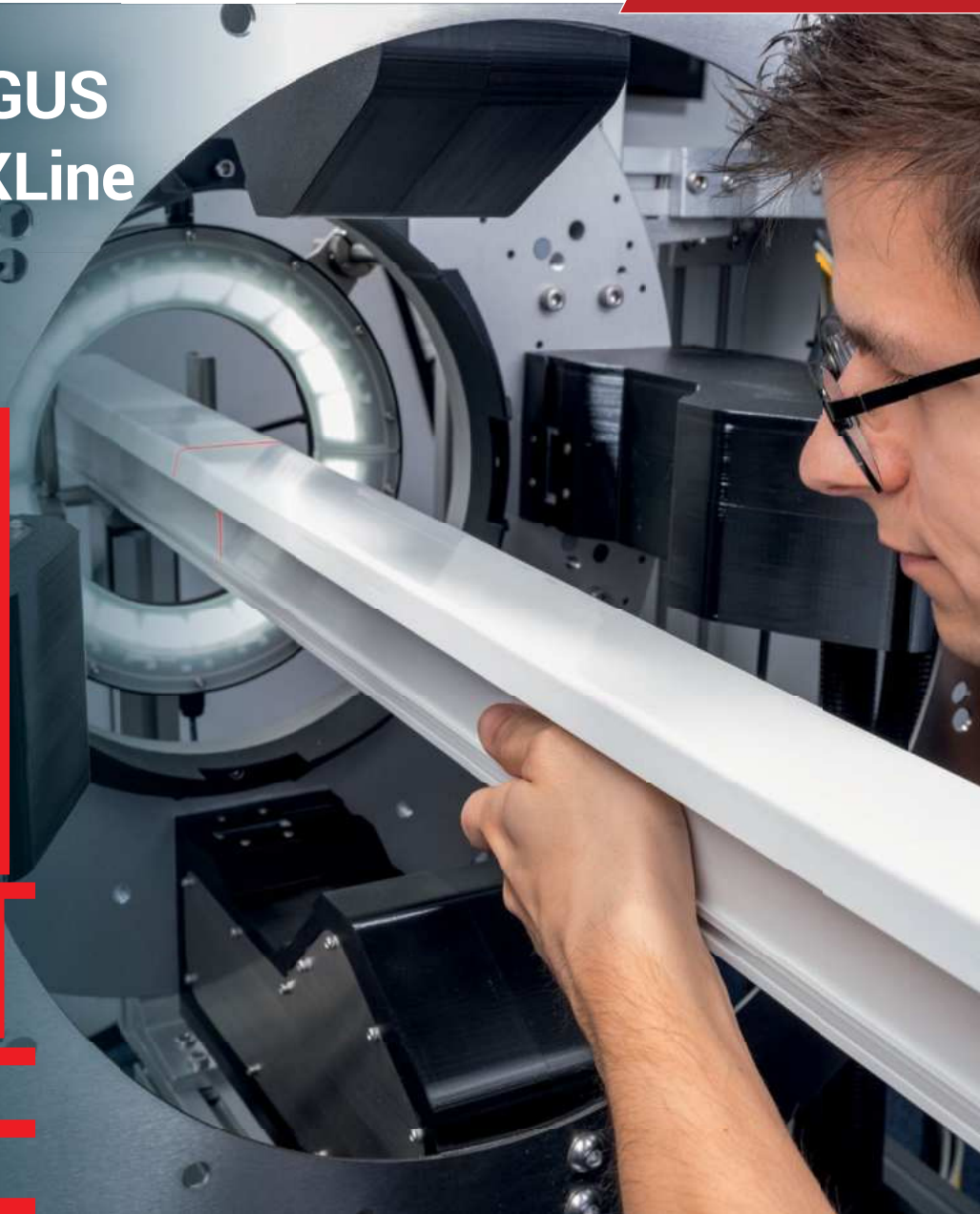

Inline Quality Inspection of Extruded Products. Surface and/or Geometry.

www.pixargus.com/xline



Regular RECYCLING Section p. 47

Stein Profile Stacker



Profile length measurement during extrusion

Measuring sensors are used to determine the length of individual profiles before a profile layer is formed.

The measured length can be used to check and correct the cutting device of the extrusion line or for documentation (quality assurance) of the produced profile lengths.



Cassette handling

The handling system allows empty cassettes to be fed into the automatic stacker and the filled cassettes to be pushed out.



**NEW
VERSION**

Completely enclosed work area
or secured with a light barrier.

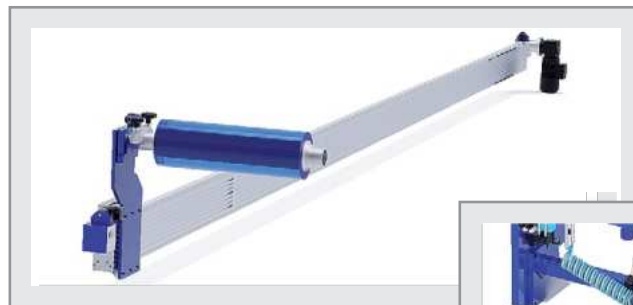

Profile interlayer

Endlessly laid as a foil between the profile layers or with individual strips laid on the layer.

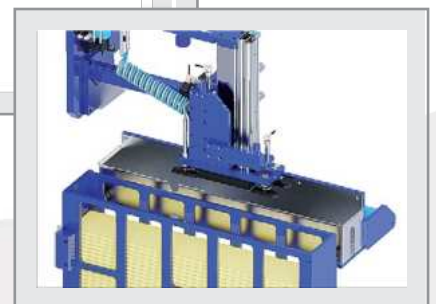

As a specialist in the field of special machine construction, we always find a solution!

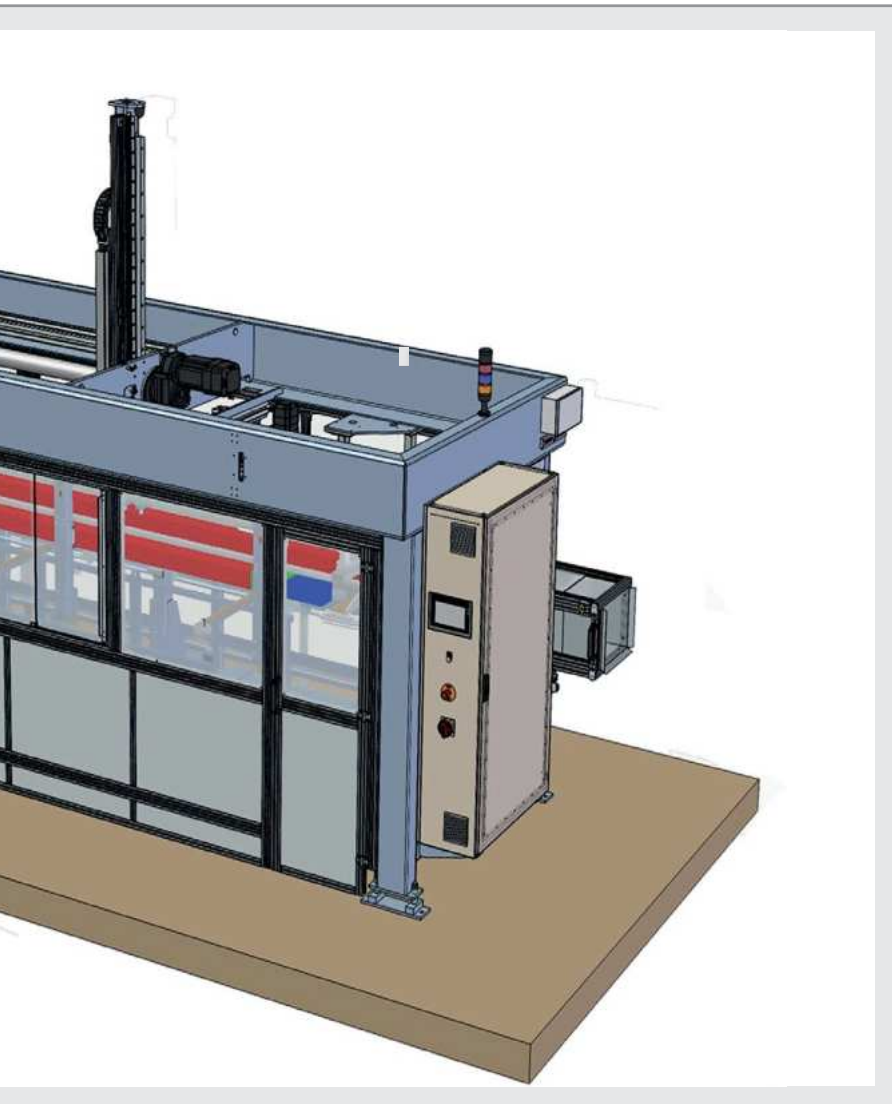

Cassette spreader

With the help of a cassette spreader it is possible to realise the same packing density of the manual packaging.

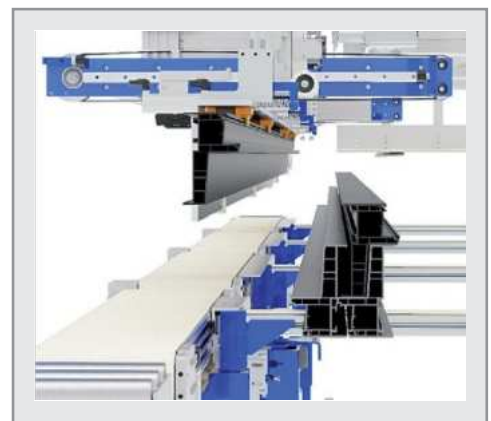

Stacking of special profiles

Stein Maschinenbau offers technical solutions for stacking of heavy and large monoblock profiles.

Based on decades of experience, we can unusual profile geometries or special layer can be evaluated for their automated stacking.



Weight determination during extrusion

With the help of special weighing units, individual profiles can be weighed before a profile layer is formed. The determined weight can be used to optimise the extrusion.



**STEIN Maschinenbau
GmbH & Co.KG**

Wartbachstrasse 9
66999 Hinterweidenthal/Germany
Tel. (+49) (0)63 96-9215-0
Fax (+49) (0)63 96-9215-25
stein@stein-maschinenbau.de
www.stein-maschinenbau.de

CONTENTS

Firms in this issue	6	Polystyrene Recycling Alliance Partners	
Imprint	7	with Mexican Plastics Part to promote	
Industry News	8	High-Impact Polystyrene Circularity	29
Calendar	8	New Recycling is Real Video Released	30
Once again, Fakuma Makes a Strong Statement on Career Opportunities in the Plastics Industry	8	Measurement and Inspection Technology	
Advanced Recycling Conference 2026	9	Technology Partnership for the	
wire & Tube 2026 – An Industry Ready for the Future	9	Spanish Market Started	32
New Sales Manager Named	10	Measurement Technology	
Women in Plastics Italy – 2026 Annual Assembly Marks Growth, new Appointments, and an Expanding International Outlook	10	Introducing New AI-Driven SIMAC® Surface Testing System	34
Support for Voluntary Sustainability Report	12	Extrusion Technologies	
Two Different Speed for 2025 and Many Clouds on the Horizon	13	Polyketone Pipe Extrusion	35
Global Management Team Strengthened	14	Extrusion Tooling	
New Strategic Direction	15	Getting the Most from Your Extrusion Tooling	37
New Packaging Solutions for Thermoforming Systems	16	Blown Film	
Spin-Off: Sensors and Measurement Technology Division to Become an Independent Company	17	Smart Solutions for High Productivity	40
Moretto in Motion – Experience, Learn, Innovate	18	Periphery, Pipe Extrusion	
Plastics Division with Spare Parts for Underwater Pelletizing Expanded	18	Advanced Calibration Technology for Plastic Pipe Extrusion	41
Measuring Moisture in Bulk Solids	20	Compounding	
Reduction in Material Usage for Plastic Packaging	21	More Quality, Less Energy – Eccentric Pelletizer EGR Optimized	42
DURACON® POM is Adopted for Ground-Breaking Crawler Transport System	22	Extrusion Technologies	
Reciprocating Head for Medical Tubing Introduced	23	New Dimension in Extrusion Technology	43
Industry News USA	24	Extrusion Technology	
SPE's ANTEC® to Drive Technical Education at NPE2027 as Part of Integrated Expo+ Education Experience	24	Misunderstood Technology – Why Many PVC Extruders Fail to Unlock the Full Potential of Twin-Screw Extrusion	44
American Foundation for a New Fund	24	Corona Treatment – Interview	
New Americas Test & Training Center Opened	26	Building on a Legend	46
Strategic Partnership – Memorandum of Understanding Signed	27	Recycling	47
Operation Clean Sweep® Releases 2025 Global Impact Report Highlighting Industry Progress	28	Retrofit Solutions for Recycling as Virgin Material Prices Increase	48
New Analysis Examines Shifting U.S.-Japan Trade Dynamics Amid Rising Tariffs and Global Uncertainty	28	European Expertise for High-Quality Plastics Recycling	49
The American National Standards Institute (ANSI) Announced as an Official Partner for World Engineering Day for Sustainable Development 2026	29	Turning Waste into Raw Materials – Recycling Diapers Instead of Burning Them	50
		Food Contact Approval for Recycled Films Obtained	51
		Next-Generation AI Platform Launched and GAINnext™ Ecosystem Expanded	52
		Successful 2025 Results – Over 37,000 Tonnes of Agricultural Plastics Recycled	54
		Producing High-Quality Regranulate Efficiently	55

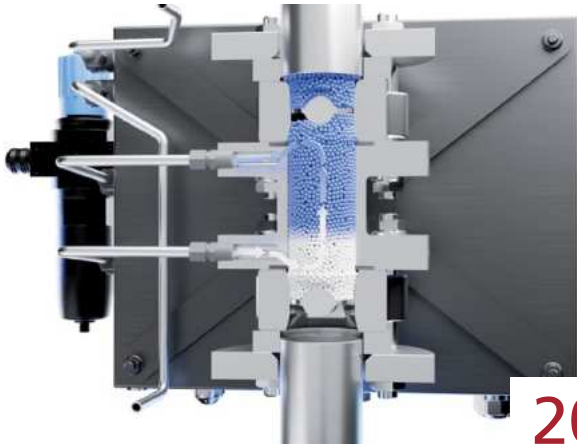

20

With the launch of the DewTector®, Coperion introduces an innovative moisture measuring device designed to provide reliable, automated online measurements of surface moisture content in bulk materials, particularly plastic pellets



32

PiXARGUS has taken a new strategic step to grow in the European plastics and rubber market by expanding its sales network on the Iberian Peninsula. Newly on board as sales representative is Comercial Douma



37

Tooling maintenance helps ensure a quality extruded product – one that meets dimensional specifications, maintains the specified minimum tolerance and is economically produced



40

The German mechanical engineering company Hosokawa Alpine presents practical solutions for system automation and digitalisation that enable customers to operate their blown film lines more efficiently, safely and economically

As a market-leading provider of adjustable calibrations, CCA provides solutions supporting the automation of plastic pipe production and covering a wide diameter range from 14 up to 2400 mm (inch sizes available)

Twin-screw extrusion has long been regarded as the reference technology for rigid PVC processing. Its capability to handle heat-sensitive materials with stable fusion and low shear makes it ideal for pipe, profile, window systems, and technical extrusions

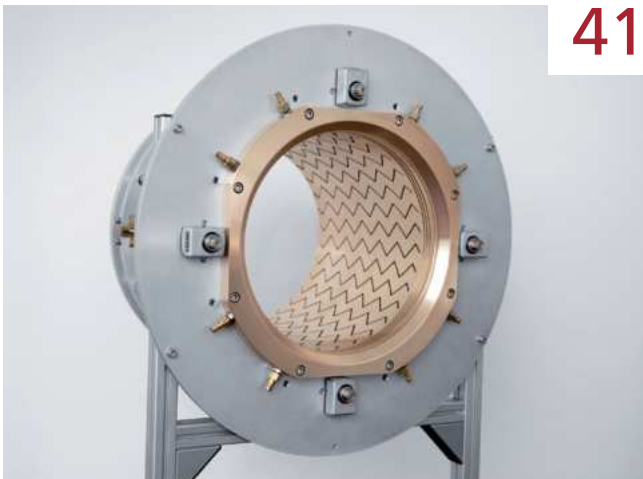

41



44

Index of Advertisers, companies and fairs referred in this issue

AMAPLAST	13	nova-Institut	9
ANSI	29	OSS Ventures	24
Baruffaldi	13	PiXARGUS	Outside Cover, 24
BB Engineering	43	PlasMec	17
BUSSLIST	15	PLASTICS	24, 28, 30
CCA	19, 41	Polyplastics	22
CONEXTRU	15, 35	Promix Solutions	21
Coperion	20, 42	PSRA	29
CuboRex	22	RAM Extrusion	44
DOW	30	Schall, P.E.	8
EREMA	49, 55	SKZ	12, 50
Extrusion Gobal	31, Inside Back Cover	Stein Maschinenbau	Inside Front Cover+3
Fakuma	8	Teknor Apex	24
Gneuss	48	TOMRA	26, 52
Gneuss MC	17	UBE	51
Guill Tool & Engineering	10, 23, 37	Vetaphone	46
Hosokawa Alpine	40	WIPS Italy	10
ICMA	23	wire & Tube	9
ILLIG	16	ZUMBACH	11, 34
Iniative ERDE	54		
iNOEX	Outside Back Cover		
Kreyenberg	18		
Lindner Washtech	14		
Messe Düsseldorf	9, 27		
Moretto	18		
motan	7		

MEDIA DATA 2026

MAGAZINE · WEBSITE · NEWSLETTER

EXTRUSION

EXPERT MEDIA ON PLASTICS EXTRUSION

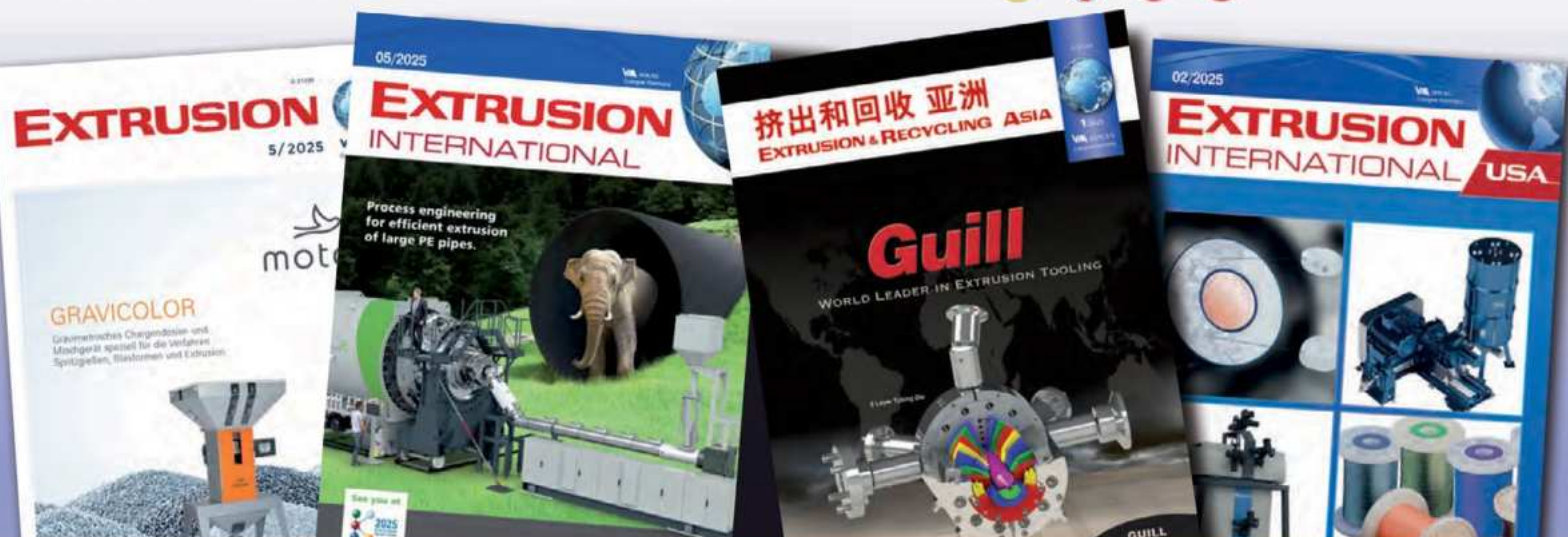

03/2026

VM VERLAG
Cologne / Germany

EXTRUSION INTERNATIONAL USA

The Extrusion International Magazine is published bimonthly by VM Verlag GmbH. P.O.Box 501812, D- 50879 Cologne, Germany

EDITOR

Bettina Jopp-Witt (Editor-in-chief)
T. +49 221 546 1539
redaktion@vm-verlag.com

ADVERTISING SALES

Martina Lerner
T.+49 6226 971515
lerner-media@t-online.de

Tanja Bolta
t.bolta@vm-verlag.com
+49 15205626122

ADMINISTRATION

Alla Kravets
T. +49 2233 949 8793
a.kravets@vm-verlag.com

PRINTING

maincontor GmbH
Dr.-Gammert-Str. 13a,
63906 Erlenbach, Germany
T.: +49 937294810811
www.maincontor.de,
info@frankhohmann.com

SALES REPRESENTATIVES

China & Asia
octavia@ringier.com.hk,
T. +852-9648-2561
maggieliu@ringiertrade.com,
T. +86-13602785446

Tokyo PR Inc. (Japan)
T. +81 (3) 3273-2731
extrusion@tokyopr.co.jp

Reprints, Translation etc

No part of this publication may be reproduced, stored in a retrieval system, or transmitted, in any form or by any means, electronic, mechanical, photographic, recording or otherwise, without prior permission of the publisher.

www.extrusion-global.com



swift
by motan

sDRY

The compact dry air dryer offers the ideal price-performance ratio for standard applications in the drying of granulate.

Visit us
Hall: 20
Stand: D30

KUTENO
09.–11. Juni 2026
Messezentrum
Bad Salzuffen



ZERO LOSS

www.motan-group.com



PLAST Milan

9 – 12 June 2026

Milan / Italy

► www.plastonline.org

SPE Extrusion Optimization

TopCon (Topical Conference)

16 - 18 June 2026

Quebec / Canada

► <http://speextrusiontopxon.technical-content.com>

Future of Advanced Recycling 2026

17 – 18 June 2026

Pittsburgh, Pennsylvania / USA

► www.wplgroup.com/aci/event/future-advanced-recycling-north-america/

Fakuma 2026

13 – 17 October 2026

Friedrichshafen / Germany

► www.fakuma-messe.de

interpack China 2026

16 – 18 November 2026

Shanghai / P.R. China

► www.interpack-cn.com

wire India and Tube India 2026

30 November – 2 December 2026

Mumbai / India

► www.wire-india.com

► www.tube-india.com

Anuga FoodTec 2027

23 – 26 February 2027

Cologne / Germany

► www.anugafoodtec.de

NPE2027

03 - 07 May 2027

Orlando, FL / USA

► <https://e.plasticsindustry.org/>

Plastasia 2027

20 – 23 May 2027

New Delhi / India

► www.plastasia.in

GREENPLAST

28 May – 1 June 2028

Milan / Italy

► www.greenplast.org



Once again, Fakuma Makes a Strong Statement on Career Opportunities in the Plastics Industry

In the wake of a successful debut, Fakuma is once again sending a strong signal in support of young talent: within the context of the 30th Fakuma, trade fair promoters P. E. Schall, in collaboration with the trade fair advisory board and PlasticsEurope Germany, will once again be hosting Career Friday on 16 October 2026 in keeping with the maxim "Mould Your Dreams, Mould Your Future". Pupils, students and young professionals are invited to experience the broad range of opportunities offered by the plastics industry first-hand.

With Career Friday, Fakuma has created a platform that specifically targets young talent and provides them with practical insights into one of Europe's most innovative industries. International exhibitors will hold exclusive events at their trade fair booths, offering insights into modern manufacturing technologies and outlining effective strategies for entering the industry.

"We don't just want to acquaint young people with various job profiles – we want to open up real career horizons," explains Bettina Schall, managing director of Schall Trade Fairs. "Career Friday brings talented individuals and companies together face-to-face in an authentic, pragmatic manner, on an equal footing." "This allows visitors to discover just how exciting and progressive the plastics industry really is."

Young visitors will benefit from direct interaction with professionals, apprentices and students employed by the exhibiting companies. This personal encounter provides realistic insights

into routine daily work, development opportunities and career paths.

Guided Tours: Bridging the Gap Between Talent and Industry

One of the key features of Career Friday involves guided tours at the trade fair. The tours are once again being organised in collaboration with PlasticsEurope Germany and rank among the highlights of the exhibition programme.

Participants will be accompanied in organised groups to registered exhibitors in a targeted manner. Company representatives will present specific career opportunities, current projects and technological innovations at their booths. At the same time, space is created for personal discussion and focused networking.

"The plastics industry is in the midst of a profound shift towards greater sustainability and circular economy," emphasises Bettina Dempewolf, head of Communications at PlasticsEurope Germany. "In particular for this reason, we need committed young professionals who will actively help shape this transformation. Career Friday is an excellent opportunity for inspiring young people to take on this task and providing them with insights into the great diversity of our industry sector."

Plastics Industry as Innovation and Sustainability Driver

The plastics industry is regarded as a key sector for numerous future-oriented challenges – from resource-effi-

cient production and lightweight design to innovative recycling solutions. Companies are investing continuously in new technologies and sustainable approaches, opening up attractive and varied career opportunities.

Feedback from the industry has been consistently positive. Leading

companies are getting involved with their own initiatives, presentations and opportunities for discussion – a clear indication of the high priority placed on developing young talent.

Well in advance, the event is generating great interest within the education sector.

Close collaboration amongst the event organisers, industry representatives and trade associations underscores the relevance of the event and ensures a varied programme that delivers lasting value for all involved.

► www.fakuma-messe.de

Advanced Recycling Conference 2026

The call for abstracts is now open for the Advanced Recycling Conference (ARC) 2026, taking place on 17–18 November 2026 in Cologne, Germany, and online. Europe's leading platform for advanced recycling brings together hands-on solutions and cutting-edge research on recycling technologies for various waste streams like plastics, polymers, textiles or automotive, highlighting progress towards a circular renewable carbon economy.

As various industries adapt to ambitious EU recycling targets and evolving market conditions, ARC 2026

will explore the latest technological, policy, and regulatory developments shaping advanced recycling across Europe and beyond. Researchers and industry professionals are invited to submit abstracts by 31 July 2026 via <https://advanced-recycling.eu/call-for-abstracts/>.

The conference covers a wide range of topics, including extrusion, dissolution, solvolysis, enzymolysis, pyrolysis, pre- and post-treatment processes, digital innovations (AI, blockchain), and life cycle assessment. With a focus on collaboration along the entire recycling value chain, ARC 2026 offers a

key meeting point for technology providers, industry, waste management, brands, investors, policymakers, and the scientific community.

As the go-to event for both practical insights and forward-looking research, ARC 2026 will also address technology selection for different waste streams, environmental impact assessment, and emerging innovations with promising applications.

nova-Institut GmbH

► www.nova-institute.eu

► <https://advanced-recycling.eu>

wire & Tube 2026 – *An Industry Ready for the Future*

Massive geopolitical challenges, disrupted supply chains, high tariffs and scarce raw materials. Yet the Düsseldorf Fairgrounds were buzzing with activity. People were discussing, developing and rethinking. Here, an entire industry demonstrated its unwavering determination to actively shape the future and break new ground.

Resilient materials are needed, including for the defence industry; the market requires reliable producers and is relying on new supply chains. This is where wire and Tube, as powerful industry platforms, came in at just the right time. The defence sector is gaining in importance; new visitor groups flocked to the exhibition stands, finding concrete solutions for high demands on materials and quality. Added to this was a supporting programme featuring exciting premieres. The trade fair as a vibrant industry event: tradition and the future go hand in hand in Düsseldorf. 2,600



exhibitors from 65 countries – proof of international appeal and a clear claim to leadership.

Alongside this, the entire value chain was showcased across some 119,000 square metres in 16 exhibition halls. The focus is always on the

future: artificial intelligence, robotics, renewable energies and the energy transition were not just buzzwords, but lived reality.

Messe Düsseldorf GmbH

► www.wire.de; www.Tube.de

New Sales Manager Named

Guill Tool announces the appointment of Stephen Ovren as the company's sales manager. The announcement was made by Chuck Paull, Chief Marketing Officer, at the company's West Warwick, Rhode Island headquarters.

Ovren obtained an M.B.A from the University of Miami Florida and his B.S. in Industrial Technology and Manufacturing Engineering from the University of Wisconsin-Stout Polythetic.

Prior to Guill, Ovren was a Senior Business Consultant at GES/GRB Consulting and General Manager at ATW Companies. The former organization provides strategic partnership through team extension to the Submarine Industrial Base, while the latter is a supplier of precision tubing and fabricated metal components for the medical, aerospace, telecommunications, industrial and defense sectors.

On March 23, 2026, Ovren became the company's Sales Manger for the Extrusion Division. His responsibilities include sales, marketing and customer service.

Commenting on this new hire, Paull said, "We're thrilled to have Stephen on our team. His previous experiences in tubing as well as work in the submarine industry are an asset."

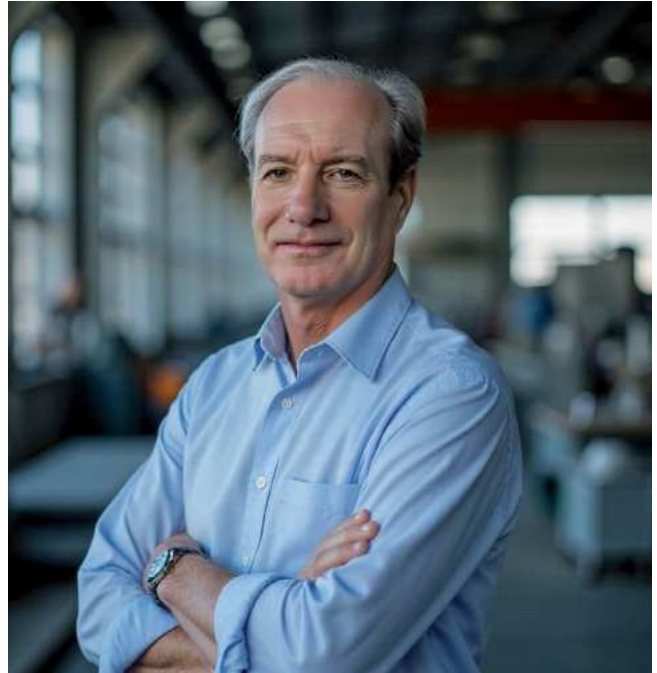

Guill Tool & Engineering
Chuck Paull, Chief Marketing Officer
 cpaul@guill.com

Women in Plastics Italy – 2026 Annual Assembly Marks Growth, new Appointments, and an Expanding International Outlook

The annual general meeting of Women in Plastics Italy (WIPS-It) took place on 13 April, at Smartt Valley in Dave-rio (Varese). A key moment in the association's calendar, the meeting confirmed the organisation's steady growth and consolidation since its establishment, with a mission to promote female talent and foster a more inclusive and sustainable culture within the plastics industry.

The assembly provided an important opportunity for reflection, discussion, and strategic planning, during which members reviewed achievements to date, ongoing activities, and the association's future outlook.

Officially founded in October 2024, Women in Plastics Italy has experienced rapid growth, doubling its membership base in a short period and building an increasingly active and engaged community. From the



outset, the association has stood out for its ability to launch concrete initiatives, foster meaningful connections, and promote a renewed sector culture grounded in inclusivity, sustainability, and the enhancement of skills.

New appointments to the Board of Directors

During the assembly, two new members were elected to the Board of Directors: Erica Cantillo and Francesca Minarini, who will contribute to

further strengthening the association's governance. Elisa Aghemo was also appointed as a member of the Board of Auditors.

These appointments represent an important step in ensuring both continuity and renewal, in line with WIPS-It's values of participation and shared responsibility.

Looking beyond national borders

Among the key outcomes of the meeting was the approval of a document drafted by the Board of Directors outlining guidelines for the use of the WIPS-It brand by international organisations interested in adopting its model.

This marks an important step in the association's growing international relevance. Similar initiatives are already emerging abroad, with WIPS Austria already established, and the association aims to both safeguard and promote its core values, ensuring that the WIPS model can be rep-

licated in different contexts while respecting local cultures and preserving its identity.

Working groups and future initiatives

Significant attention was devoted to the association's working groups, which are at the heart of its activities. They provided updates on completed projects, ongoing initiatives, and new proposals currently under development. This was a key moment to share results, gather input, and strengthen active member engagement.

A day of networking and professional development

Alongside the institutional agenda, the event reaffirmed its strong networking dimension, offering numerous opportunities for exchange among participants.

The day concluded with a visit to the Smartt Valley facilities, followed by a final talk on social selling, reflecting the association's ongoing commitment to supporting the professional development of its members through relevant tools and skills.

"The growth we have experienced in recent months was far from guar-

anteed: while our goal was clear, achieving it required focus, dedication, professionalism, and strong shared determination. Today, Women in Plastics Italy is a vibrant and dynamic network, actively connecting individuals, businesses, and institutions. It is a space where genuine dialogue takes place, and where many women finally find an environment for listening, expression, and growth. Change is not something to wait for, it is already happening, and we are actively part of it," said President Miriam Olivi.

➔ wips-italy.it
➔ info@wips-italy.it

Zumbach
SWISS PRIME MEASURING SINCE 1957

NEW



AI-Driven SIMAC®

Pipe & Hose Surface Quality Inspection System

Benefits:

- ✓ Real time detection through artificial intelligence
- ✓ Fast model recalibration
- ✓ Intelligent defects classification
- ✓ Statistical monitoring of defect frequency and distribution
- ✓ Identification of periodic or localised patterns
- ✓ Filtering of non critical defects based on class



300

Line speed
(m/min)



2

Min. object
diameter (mm)



108

Max. object
diameter (mm)



140,000

Scan rate
(scans/s)

SWISS
DESIGNED &
ENGINEERED



Two Different Speed for 2025 and Many Clouds on the Horizon

In line with the full-year forecasts published towards the end of last year, the Amaplast Study Center – a trade association affiliated with CONFINDUSTRIA that brings together over 170 manufacturers – estimates that the Italian industry of machinery, equipment, and moulds for plastics and rubber closed the year 2025 with a decrease in production on the order of five percentage points, and with a value of 4.4 billion euros. This represents a slowdown with respect to the previous year, 2024, where a limited deceleration was recorded. For comparison, the Germans – the Italians' direct competitors – in 2024 had already begun recording a significant slump in orders, sales, and exports.

Italian exports for the sector, which account for three quarters of production, also recorded a drop of 5%, coming in at just barely over 3.4 billion euros.

With respect to the weakness in sales abroad, imports of technology recorded a surge of nearly twenty-four percentage points over 2024, confirming robust domestic demand. This is clearly due partially to the effects of the incentives implemented by the Industry 4.0 and 5.0 Plans, in spite of difficulties in accessing them and delays in the enactment of the various associated implementation decrees. These issues are also critical in this first quarter of 2026 in the implementation of measures regarding the new "hyper-amortization" of investments in capital equipment through September 2028.

Given these dynamics, the balance of trade is significantly reduced: after the record of 2.65 billion reached in 2024, it has slipped back to 2.24 billion.

The international context in 2025 was characterized principally by uncertainties caused by the introduction of tariffs by the Trump administration which, beyond the "reciprocal" component, raise the tariffs on steel and aluminium components in certain types of machinery, components, and moulds for plastics and rubber.

The situation was worsened by the progressive devaluation of the dollar with respect to the euro. It deteriorated further with the outbreak of the troubling war in the Middle East, which has triggered an energy crisis that has already begun to have a strong negative impact on the European plastics and rubber processing industry by increasing the costs of natural gas, petroleum, and raw materials and generating uncertainties about the availability of materials.

This situation is the source of significant concern among Italian manufacturers of plastics and rubber processing machinery, with a host of factors that threaten to compromise the propensity for investment in the domestic market – here understood as both the Italian and the European market, the latter historically the main destination for Italian exports – and challenges in store with the implementation of the new European Packaging and Packaging Waste Regulation (PPWR).

Not surprisingly, sales to Germany, which has always been Italy's prime trade partner, have fallen for the second consecutive year. The German plastics and rubber industry recorded losses across the board in 2025 according to estimates by various trade associations: -4% by volume in polymer production; -2% of processed plastic products;

-6% for rubber products; and -5% in revenues for machinery manufacturers.

Exports to processors in France, another major export destination in the EU, have also fallen off.

Within the top ten destination markets, these negative trends have fortunately been compensated by an increase in sales to Spain, Poland, and Romania.

On the other hand, as of last December, the abovementioned issues have not yet caused the feared collapse of Italian exports to the American market. Instead we have witnessed an increase of almost nine percentage points. U.S. domestic machinery production meets only a limited share of local demand and so American plastics and rubber processors have continued to turn to Italian and other manufacturers to acquire advanced technology.

Sales to China have continued to increase at a steady pace but those to India even more so, more than tripling in the past ten years: the growing incentives provided by the Make in India programme have generated a strong acceleration of demand by local manufacturers, who require increasingly high quality technological systems. So this is a market with notable potentials, most of which have yet to be developed. The recently signed free trade agreement should facilitate this process.

On the other hand, two other important countries that recently rejoined the group of top ten destination markets have produced disappointing results for Italian manufacturers: sales to Turkey have plunged by one third, breaking a five-year robust growth trend, and those to Brazil performed even worse, -45%, although this is relative to the abnormally high peak in 2024 and actually represents a return to the average figures recorded in the previous period. We are naturally looking forward to the implementation of the EU-Mercosur treaty, which could inject new dynamism into trade with Brazil and South America generally.

As regards product categories, exports overall have shown lacklustre or diminishing performance for most of the machinery types accounting for the largest share of the total, starting with extruders (falling from nearly 400 to 350 million euros), blow-moulding machines (from 212 to 198 million), flexography machines (from 181 to 164 million), and moulds (from 752 to 721 million). Injection moulding machines were the only ones to buck the trend, with sales rising from 194 to 199 million.

In this complex situation, Amaplast member companies finished the year 2025 with a downturn in revenues on the order of five percentage points while nevertheless succeeding in maintaining employment levels (+0.5%). Within this group, 54% of the companies closed the year with a drop in sales.

It has never been so difficult to venture forecasts for the coming months: there are too many unknowns that continue to arrive and overlap on the international level, aggravating the climate of uncertainty that companies are facing, with many historical destination markets characterized by greater difficulty of access.

There will be an opportunity for discussion and updates among international operators in the plastics and rubber

industry this year at PLAST 2026 in Milan (9-12 June), organized by Promaplast srl, the Amaplast service company.

As the exhibition slowly takes shape – with over 160 new participants with respect to the previous edition, 30% of them foreign companies – the organization of associated

events and the reception of hundreds of qualified buyers is well underway, in collaboration with Agenzia ICE and the principal foreign manufacturers associations.

➔ www.amaplast.org
➔ www.plastonline.org

Support for Voluntary Sustainability Report

Even without a legal requirement, a sustainability report can give SMEs a decisive competitive advantage. The voluntary VSME standard helps companies respond efficiently to inquiries from major business partners and promote transparency in the supply chain. The SKZ Plastics Center provides comprehensive support to companies in this process – from analyzing relevant key performance indicators to producing the final documentation.



The SKZ Plastics Center assists companies in preparing structured sustainability reports in accordance with the VSME standard (Photo: AI-generated)

On February 2026, the EU Council finally adopted the Omnibus I package, thereby ending the uncertainty surrounding sustainability reporting requirements. Companies with 1,000 or more employees or net revenue of 450 million euros or more are required to publish a sustainability report. These companies now need sustainability information not only about their own activities but also about those of their supply chain. With the voluntary reporting standard VSME, small and medium-sized enterprises (SMEs) have been given a shield to ef-

ficiently handle the requests of their large business partners.

The Omnibus I package thus reduces the number of affected companies by approximately 90%, but at the same time places greater emphasis on voluntary sustainability reporting (Voluntary Sustainability Reporting Standard for non-listed SMEs (VSME)). Although the sustainability report is voluntary, it becomes a strategic advantage – a sort of “shield” – against the “trickle-down effect.” This is because many companies subject to mandatory reporting now require sustainability information

from their suppliers in order to meet their own reporting and disclosure obligations. In practice, this has typically been done through comprehensive surveys directed at sustainability management or executive management. These teams then have their hands full collecting the necessary data internally and compiling it individually.



- Custom made
- Extrusion line
- Cable ducts
- Slotting
- Jointing
- Drainage
- Corrugated pipes
- Assembling
- Punching
- Cut to length
- Perforating
- Roller shutters
- Milling
- Smooth pipes
- Technical profiles
- Socket welding
- Diameter
- Drilling
- Rotary punching
- Geometry
- Guillotines



SUCCESSFUL SOLUTIONS FOR PIPES AND PROFILES SINCE 1953

info@baruffaldi.eu
www.baruffaldi.eu



With the update to regulatory requirements under the Omnibus Regulation, larger companies will in future only be permitted to request sustainability information from their suppliers that is also included in the VSME sustainability report. For small and medium-sized enterprises, this represents a significant efficiency gain: instead of responding to extensive individual requests from their customers, they can simply refer to their VSME report, which bundles all relevant information. SMEs that have already established internal structures for data collection and systematically documented their key performance indicators in the VSME format are thus well prepared.

The VSME standard is divided into modules covering the areas of "General," "Environment," "Social," and "Corporate Governance." In addition

to eleven basic modules, nine comprehensive modules are available. In total, the standard comprises around 40 data points in the basic modules and 33 in the comprehensive modules. In contrast to the complex double materiality analysis required for CSRD reporting, the VSME takes a significantly simpler approach: for individual indicators, only an "if applicable" principle applies.

The Regional Competence Center KARE prepares VSME sustainability reports for plastics processing and recycling companies. Experience to date shows that the data required for the approximately 20 modules can be efficiently collected – for example, from existing ISO certifications. The SKZ provides comprehensive support to companies in this process: from analyzing relevant key performance indicators and structuring the content to

producing the final documentation in accordance with the VSME standard.

"Especially for small and medium-sized enterprises, having their own sustainability report offers the opportunity to position themselves professionally both organizationally and communicatively, to highlight their own achievements, and at the same time to significantly reduce the effort involved in responding to customer inquiries," explains Jonathan Lambers, Group Leader for Transformation of the Plastics Industry at the SKZ. Those interested in support services are asked to contact Jonathan Lambers directly.

The SKZ Plastics Center
Jonathan Lambers
Group Manager | Transformation
of the plastics industry
j.lambers@skz.de

Global Management Team Strengthened

Lindner Washtech is one of the world's leading manufacturers of washing systems for the plastics processing industry. With more than 250 projects implemented worldwide, extensive process expertise, and a technology partnership with EREMA, the company is increasing its focus on innovative end-to-end solutions, from waste plastic collection to the finished recyclate. Marcel Willberg, part of the Lindner Washtech team for a good ten years, has been appointed as Managing Director alongside Georg Krenn and will in future be primarily responsible for global sales. Willberg's appointment reflects a clear commitment over the longer term to developing top management from within the ranks of the organisation.

Marcel Willberg has been an integral part of the Lindner Washtech team for the best part of a decade. He has extensive knowledge of plastics recycling, from sorting, pre-shredding, cold and hot washing, through to drying and quality assurance. Previously, working as Head of Sales, he and his team have been supporting customers in Europe, the USA, Asia, and the Middle East, successfully implementing projects of varying sizes and complexity. These range from large-scale systems for municipal waste management companies to custom-built systems for international plastics processors and petrochemical corporations.

Part of his recipe for success is his keen awareness of customer needs and market trends. „Marcel Willberg's skillset goes far beyond the technical specifications. He understands his client's business scenarios and devises tailor-made solutions together with them and his team," says Matthias Egarter, CEO of Linder. „I am proud that we have been able to develop leadership personalities like him from within our ranks."



Marcel Willberg (right) and Georg Krenn (left) now jointly manage Lindner Washtech. The management duo combines Krenn's many years of experience in strategic operations and technical expertise with Willberg's strength in global sales (Copyright © Linder-Recyclingtech)

Marcel Willberg enters his new job alongside Georg Krenn, who, as Managing Director, has shaped Lindner Washtech and established its position on the international market since the company was founded. The management duo combines Krenn's many years of experience in strategic operations and technical expertise with Willberg's strength in global sales; a combination that puts the company in a perfect position for its next phase of growth.

New Strategic Direction



*Dr. Philip Nising,
CEO BUSSLIST Group*



*Karsten Gudemann,
COO BUSSLIST Group*



*Stephan Bühler, Owner
of Jakob Müller Holding AG*

BUSS AG, LIST Technology AG and BBA Innova AG formally unite under a new group name: BUSSLIST Group. The three Swiss-based companies, each a specialist in demanding process technology applications, now operate under one leadership and one strategic commitment – while maintaining their established technology brands and customer relationships.

BUSSLIST Group brings together three complementary process technologies:

- the LIST KneaderReactor for continuous high-viscosity processing, reactions, devolatilization, drying, crystallization, desublimation and dissolving;
- the BUSS Co-Kneader for continuous temperature- and shear-sensitive compounding of demanding materials;
- and BBA Cooling Technology for the precise solidification, breaking and finishing of viscous materials.

The three technologies cover critical and adjacent steps in process engineering across the chemical, polymer, fiber, food and life science industries. The group is part of the Process Solutions division of Jakob Müller Holding AG, a Swiss family-owned industrial group.

Three technologies. One process understanding.

What unites the three companies is not a production line, but a shared foundation: decades of deep process knowledge, built through thousands of realized production lines across the world's most demanding industries. BUSSLIST Group positions itself as the partner for customers who require process technology that sets new standards – from the first feasibility test to industrial-scale production.

With more than 3,500 installed BUSS Ko-Kneader systems, a vast LIST KneaderReactor installed base across specialty chemical, fiber and food applications, and BBA cooling systems in use across powder coating, pharma and life science production, BUSSLIST Group combines proven technology with a broad process engineering footprint.

All existing business relationships continue under the known legal entities. Legal consolidation will be completed over the coming months, with direct outreach to affected customers and partners where relevant.

BUSSLIST Group is part of the Process Solutions division of Jakob Müller Holding AG.

BUSSLIST Group
 www.busslist.com

CONEXTRU

To ensure production with the tightest tolerances and lowest overweight, the nozzles on PO pipe heads are designed with thermal wall-thickness centering.

- **MORE PRECISE THAN MECHANICAL CANTERING**
- **VERY HIGH COST-EFFECTIVENESS**
- **EASY TO RETROFIT FOR ALL DIAMETER RANGES**



www.conextru.eu | dobrowsky.j@conextru.eu

PO PIPE HEADS



New Packing Solutions for Thermoforming Systems

ILLIG packaging solutions is expanding its end-of-line automation portfolio with two new box filling units. The new systems enable fully automated cartoning of products directly downstream of the thermoforming process.

With the new BFU 300 and the high-performance variant BFU 500, the company now offers fully integrated box filling units (BFU) based entirely on its own drive, software and control technology, replacing third-party systems. The aim is to provide customers with more flexible, high-performance and seamlessly integrated packaging solutions from a single source. The performance of the thermoforming systems remains unaffected by the new packers – a key advantage compared to standard market solutions. Both packers are positioned in a stationary setup, eliminating the need for machine movement during tool changes.

Initially, the new box packers will be available for RDM/RDML systems, with solutions for RDK systems currently in development.

“With the new box packers, we are closing an important gap in the end-of-line segment and enabling a consistent process logic from thermoforming through to cartoning,” says Christoph Gusenleitner, CEO of ILLIG. Our customers benefit from higher performance, greater flexibility in packing patterns and a unified operation and service environment.”

Two versions for different requirements

The new end-of-line solution is available in two versions. The BFU 300 is designed for standardized applications with round, standard parts and conventional stacking configurations. Carton layers are transferred directly from the cross conveyor into the packer and placed into the carton via a lifting system. Thanks to its reduced mechanical complexity and limited number of format and changeover parts, this variant is particularly suitable for customers seeking a robust, cost-efficient solution with solid performance.



ILLIG Box Filling Unit (BFU) (Source: ILLIG)

For more demanding applications with high cycle rates, tight packing schemes or non-round parts, the BFU 500 offers an optimal solution. This packer is equipped with servo-driven pitch adjustment and a servo-driven gripper, enabling reliable processing of a wide range of stacking configurations, including unstable part stacks, as well as complex part geometries. The system includes two servo-driven pushers that can be used flexibly.

For high-performance requirements, a double-push mechanism is applied. For stack-critical parts, a counterholder ensures continuous support of the part stacks on both sides throughout the packing process. Tight packing schemes can be achieved through interleaving individual stacks or by forming A or B layers.

Both systems support the processing of complete carton layers, which accelerates the packing process and increases process stability. Depending on the configuration and application, up to nine carton layers per minute can be achieved.

100 percent ILLIG – from control to service

The new box packers are fully integrated into the ILLIG system environment. Drive technology, software, user interface, commissioning and

service are all provided by the German technology company. Both the thermoforming system and the packer are operated via the digital “ILLIG EasyTouch” control panel, enabling convenient control of all functions across the entire line – a clear advantage compared to third-party systems. In addition, the systems can be easily connected to further automation solutions, such as loading and unloading systems, automated guided vehicles or warehouse logistics.

An RDM system with integrated BFU will be available for demonstration at the ILLIG Technology Center (ITC) from July 2026. Quotations for RDM systems are available immediately.

End-to-end solutions as a competitive advantage

With the new box packing solutions, ILLIG is further strengthening its position as a provider of integrated packaging systems. Customers benefit from clearly defined interfaces, consistent operating logic and a single point of contact throughout the entire lifecycle of the system.

„The market is increasingly demanding end-to-end, scalable process chains instead of standalone machines,” adds Gusenleitner. „With our new box packers, we deliver this continuity at the end of the line and enable our customers to achieve higher line efficiency.”

Spin-Off: Sensors and Measurement Technology Division to Become an Independent Company

Gneuss Kunststofftechnik GmbH is restructuring its sensor and measurement technology division. As of May 1, 2026, the operational business is fully transferred to the newly founded Gneuss MC GmbH & Co. KG.

This move is a response to the division's continuous growth in recent years. Rising demand and increasing technological complexity mean that a more independent organisational structure is necessary.

The new company will consolidate all activities within the Measurement & Controls division, creating a clear structure for further business development. All division employees will transfer to the newly established company.

Gneuss MC develops and manufactures sensor solutions for pressure and temperature measurement in extrusion processes. These systems are designed for demanding industrial applications and ensure reliable measurements even under conditions such



as abrasion, corrosion and high temperatures.

Another focus is on customer-specific solutions: Thanks to its in-house manufacturing capabilities, Gneuss can produce both standardised and custom-designed sensors. The portfolio is complemented by digital technologies, including fully digital sensors and RFID-based systems for measuring and monitoring equipment.

“With this spin-off, we are creating the structural conditions to consistently further develop our sensor and measurement technologies and strengthen our position as a technology leader in the long term,” says Dr Stephan Gneuss.

Gneuss MC GmbH & Co. KG
www.gneuss-mc.com

AD - WWW.STUDIOGRAFFICO2M.IT

WE DON'T MIX, WE MAKE MACHINES THAT DO IT PERFECTLY!

9-12 INTERNATIONAL EXHIBITION FOR PLASTICS AND RUBBER INDUSTRIES
 JUNE 2026 MILANO

 PLASTONLINE.ORG
Hall 13 - Stand F33 / G26

plasmec
 Excellence in Mixing

Via Europa, 79 - 21015 Lonate Pozzolo (VA) ITALY
 Tel. +39 0331 301.648 - comm@plasmec.it
www.plasmec.it

Moretto in Motion – Experience, Learn, Innovate

Moretto has launched the “Moretto in Motion 2026” tour, a roadshow that brings the most advanced technologies for the plastics processing industry directly to customers.

The events calendar begins in Italy and then extends to key markets both within and outside Europe, including Poland, Germany, Croatia, the Netherlands, Belgium and Spain, right through to England.

This is an exclusive innovation hub where customers can experience the quality, precision engineering and energy efficiency of Moretto products. A comprehensive experience featuring expert-led presentations, hands-on simulations and interactive technical demonstrations. Having Moretto technology on site enables the company to build a closer relationship with customers, analyse their needs immediately and explain in real time how the proposed solu-



tions can boost productivity and improve plastics processing.

The ‘Moretto in Motion’ tour offers a comprehensive overview of Moretto’s integrated solutions for the

plastics processing industry, covering conveying, drying, dosing, storage, pelletising, temperature control and cooling. With 169 international patents, Moretto is the first choice for customers seeking superior technology and operational efficiency.

Convinced that the exchange of specialist knowledge drives innovation and that the contribution of younger generations is essential for bringing fresh perspectives, the tour also includes visits to technical colleges and universities. This initiative combines professional experience with the creativity of students to bridge the gap between education and the world of work.

The tour aims to foster strategic synergies, offer expert advice and provide tailor-made solutions for an increasingly demanding plastics industry.



Moretto S.p.A.

► www.moretto.com

Plastics Division with Spare Parts for Underwater Pelletizing Expanded

The mechanical engineering company Kreyenborg entered the aftermarket segment for underwater pelletizing (UWP) beginning in April 2026. Their decades of know-how in the plastics sector are presently being expanded with an all-inclusive service for systems installed in the market offering spare parts, mod-

ernization, and servicing requirements. Plates carriers and knives as well as retrofitting components and services will become available from Kreyenborg in the next few months. Above all, what customers with service needs are missing is accessibility to competent people, product availability on short notice,

and maintenance service. The new division addresses these needs and complements the two business units focused on infrared technology for the plastics/ plastics recycling and the food industry.

Udo Gielen, managing partner and CEO of Kreyenborg, can build on a solid framework of experience in the



expansion of this new business unit. He has been responsible for the sale of UWP systems for years and knows the subject matter in great detail. He also has a team of former colleagues and consultants from the plastics industry on board to support the Kreyenborg team. New partnerships have already emerged from this global network.

"For years", concedes Gielen „we had to reject customer requests for spare parts and service for UWP and refer them to others," and he explains why Kreyenborg is now re-entering this area of the business: „As a medium-sized company, we can and we want to close the gap in the market that large companies cannot afford to fill at the scale that customers would like, due to their concentration on large-scale systems and especially on new business."

Kreyenborg therefore focuses on the following services: accessible personal contacts, fast delivery times enabled by availability of compatible spare parts from their location in the Münsterland region, technical advice for existing systems, and an overall high level of quality, which Kreyenborg has always stood for. „Our aim," says Gielen, „is to offer customers service that has thus far been lacking in the market. Working with us should help them to reduce downtimes, and to be able to operate their plants more economically."

Kreyenborg has a history of technical expertise in the plastics sector and mechanical engineering, as well as a good understanding of processes, and with its product portfolio is well-positioned for expansion into the aftermarket business. Their Infrared technology business for plastics and food won't be affected directly by the expansion. However, Kreyenborg's plastics sector will benefit overall from the expansion in the spare parts sector, because the company is also investing in the technical center (trial center) and IT systems, among other areas.

Kreyenborg GmbH & Co. KG
 ► www.kreyenborg.com

hoch5.com

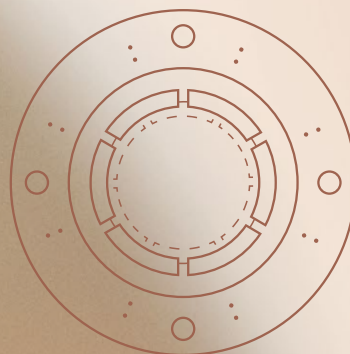

CCA

The Original

Since 2005

Quality is our Priority

CCA develops high-performance calibration sleeves for plastic pipe extrusion:

- from \varnothing 12 mm up to \varnothing 2.400 mm pipe outside diameter

- precisely matched to the production requirements of our international customers

Rely on quality „Made in Germany“ – celebrating 20 years in 2025.



www.ccagmbh.de

Measuring Moisture in Bulk Solids

With the launch of the DewTector®, Coperion introduces an innovative moisture measuring device designed to provide reliable, automated online measurements of surface moisture content in bulk materials, particularly plastic pellets. The patent-pending device offers an economical, simple and reliable method to help plastic manufacturers and recyclers monitor moisture levels more efficiently. It addresses a critical challenge faced by processors in maintaining both product quality and maintaining compliance with industry standards.

The DewTector uses a straightforward approach □ it introduces a partial flow of bulk solids into a pressure-tight product chamber. The system determines the moisture content by analyzing the moisture released into the air flow. As the air absorbs moisture, it is analyzed by a hygrometer that measures only water content. This targeted detection ensures reliable results unaffected by other substances or changes in material composition. The system neither requires extensive calibration, nor the use of chemicals for different materials or recipes, making it easy to operate and maintain. The system achieves an accuracy of +5% to -15% across moisture levels ranging from several thousand ppm to a few hundred ppm, with up to ten measurements per hour.

Challenges of Moisture Measurement in Plastics

Plastic manufacturers often face the challenge of moisture entering their final products, which can originate from

A cross-sectional view of the DewTector's product chamber, illustrating the air flow. The direct measurement approach using a hygrometer eliminates the need for complex calibrations for each formulation

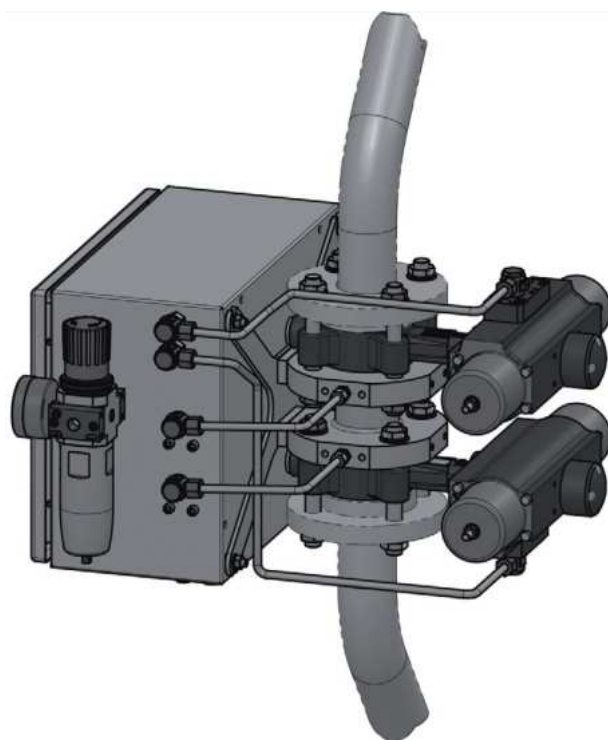
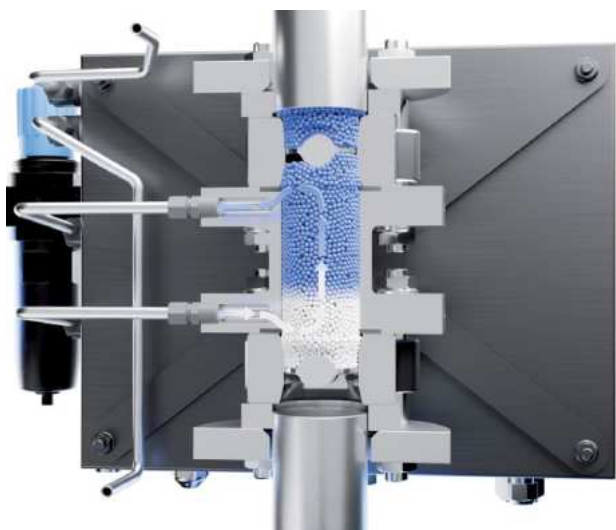

DewTector in a typical bypass line configuration. Its compact design, with a height of only 184 mm (flange to flange), simplifies process integration (Images: Coperion GmbH, Weingarten, Germany)

various sources such as insufficient drying, defective water separators, leaking wash nozzles, or environmental factors like rain and condensation. If moisture levels go undetected, it can lead to costly product complaints and reputational damages. Additionally, processors must adhere to strict moisture content limits to ensure high-quality output, and the recycling sector requires dry input materials for effective processing.

Traditionally, moisture measurement has been labor-intensive and prone to inaccuracies, often relying on sporadic manual assessments of relative humidity in bags and containers. Existing automated methods, such as capacitive and microwave resonance techniques are typically complex, expensive, and require extensive calibration for different formulations, making them impractical for many users.

By simplifying moisture measurement and reducing the labor and time spent on manual sampling and analysis, the DewTector enhances operational efficiency while providing accurate, real-time data critical for process control.

Reduction in Material Usage for Plastic Packaging

Plastics are an integral part of the packaging industry: they provide reliable protection for products, often have a lower carbon footprint than alternative materials, and can be processed efficiently. At the same time, pressure is mounting on manufacturers to conserve resources and further reduce raw material use – without compromising on stability, functionality or recyclability. With the introduction of the EUPPWR, from 2030 onwards only packaging that is fully recyclable may be placed on the market; in addition, there are ambitious targets for the use of recycled materials. Promix Solutions offers an economically and environmentally sound solution to these challenges: Microcell technology. It typically reduces packaging weight by around 20%, fully preserves mechanical properties and, at the same time, enables true recyclability.

Lighter packaging – same performance – significant cost savings

Microcell technology involves incorporating environmentally neutral gases such as CO₂ or N₂ into the plastic. This creates a fine-pored, microcellular foam structure. Cell size and cell distribution are crucial: a very fine and homogeneous structure ensures that

cups or trays achieve the same stability as conventionally manufactured packaging even after thermoforming – despite a significantly reduced density.

A typical extrusion line for packaging films with a throughput of 800 kg/h saves up to 3.8 tonnes of plastic per day using Microcell technology. This equates to around €3,800 per day or over €80,000 per month. Extrapolated over a year, this results in a reduction of around 1,000 tonnes of plastic per line.

The lower film weight for the same film thickness not only reduces energy consumption during thermoforming but also reduces transport weight – which leads to an overall improvement in the carbon footprint. The technology is suitable for virtually all polymers and can be seamlessly integrated into both existing and new production lines.

Environmentally friendly and fully recyclable

As Microcell uses environmentally neutral blowing agents and contains no environmentally harmful additives, the packaging remains fully recyclable. Even production waste, such as that generated during thermoforming, can be easily recycled, as the additive does not accumulate in the material as is the case with chemical blowing agents.

Microcell technology is suitable for a wide range of packaging applications produced using extrusion and thermoforming processes: food packaging such as pots or trays, boxes and technical packaging, as well as form-fill-seal (FFS) applications.

Case study: The 'lightweight' yoghurt pot

In the case of yoghurt pots, which are often produced using the FFS process, Microcell enables a 20 to 25% reduction in material usage without compromising on shelf life or product protection. Whilst polystyrene is traditionally used, polypropylene and polyester are becoming increasingly important.

Case study: PP clamshell tray

In a 3-layer PP clamshell tray, the Microcell core layer forms the heart of the design. Sandwiched between two solid outer layers, it significantly improves insulation and withstands temperatures of up to 100°C. The foam structure reduces the material density considerably – in this example by 40%.

Microcell PP is a sustainable alternative to polystyrene or paper-coated solutions. As a mono-material, it fully complies with the requirements of the European Packaging and Packaging Waste Regulation

Left: Yoghurt pots manufactured using Microcell technology save 20–25% plastic.

Right: Microcell structure in the core layer of an FFS film (Images: Promix Solutions AG)

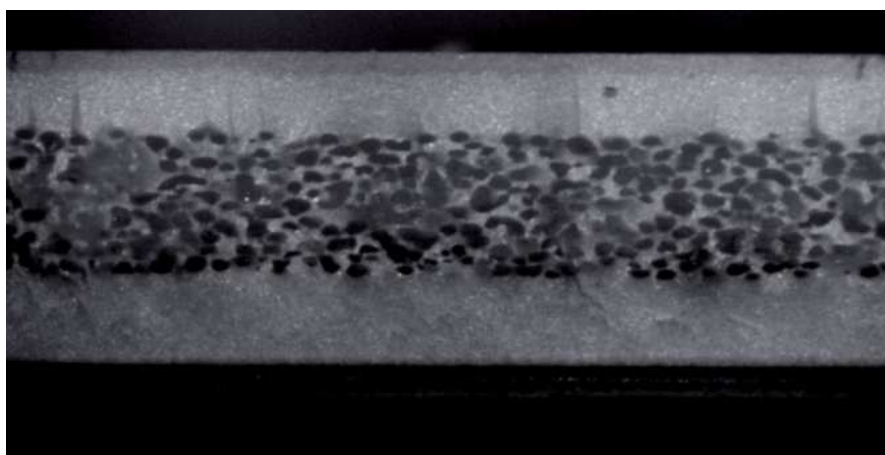

(PPWR) and is fully recyclable. Furthermore, the process enables high-quality, cost-effective products for hot-fill applications, including disposable coffee cups.

Environmentally friendly, cost-effective, future-proof

Microcell combines environmental benefits with economic efficiency. Through the use of environmentally neutral propellants, significant material savings and full recyclability, the technology paves the way for sustainable, cost-effective and regulatory-compliant packaging solutions – today and in the future.



(Image: KGL S.A.)

Promix Solutions AG

www.promix-solutions.com

DURACON® POM is Adopted for Ground-Breaking Crawler Transport System

Polyplastics' DURACON® POM resin has been selected for use in a unique crawler track transport system developed by Tokyo-based CuboRex Co., Ltd., a leading supplier of innovative mobility solutions. The unique crawler track transport system, which significantly improves work efficiency at factory and construction sites compared to conventional caster-equipped carts, includes a structural crawler covering made of DURACON® POM.

DURACON® POM was selected for the white components of the crawler. It was chosen for its high load-bearing capacity, providing the strength to withstand heavy-duty material handling at manufacturing sites. POM also boasts excellent friction properties, delivering stable performance in both static and dynamic friction. It offers durability and reliability and meets destruction criteria even in harsh field environments. DURACON® POM was adopted as the optimal solution following comparative testing with other resins such as PA.

CuboRex's trolley crawlers can be easily installed on existing trolleys.

The increased contact area reduces the load per unit area (ground pressure), decreasing friction resistance and sinking. The force required for operation is significantly reduced, enabling smooth travel even over steps and uneven terrain. Under similar conditions, turning performance also improves. Maneuvers that were arduous with conventional casters become easier, substantially reducing operator strain. Coordination with tow trucks and Automated Guided Vehicles (AGVs) also becomes smoother, preventing time loss due to stops or dropped cargo.

The demand for material handling is growing, with significant potential anticipated even within the domestic Japanese market. The introduction of crawlers for carts eliminates the need to purchase new dedicated transport carts, enabling a dramatic improvement in operational efficiency while utilizing existing equipment. This solution, which simultaneously achieves cost reduction and enhanced safety, holds great potential in the global market as well. Applications across diverse industries, including logistics,



DURACON® is a registered trademark of Polyplastics Co., Ltd. in Japan and other countries (Source: Polyplastics Co., Ltd.)

manufacturing, and construction are anticipated in the future.

This case study demonstrates that material selection can transform on-site productivity, going beyond mere material supply. DURACON® POM served as a key material supporting CuboRex's innovative ideas, contributing to the efficiency of transport operations.

CuboRex Co., Ltd.

https://cuborex.com

Polyplastics Co., Ltd.
info@polyplastics.com

Reciprocating Head for Medical Tubing Introduced

Guill Tool has released its new reciprocating head. The traditional tip and die assembly is replaced with a linear reciprocating assembly that changes the tube's profile within a given length. This process is repeated throughout a single extrusion run without interruptions. Cutting capability, in association with the extrusion speed, cuts the finished product to length.

While cost and value stream activities are reduced, quality is improved. Only one extrusion run is needed to produce a finished product, as opposed to multiple extrusion runs with tooling changes along with a manual assembly operation to connect different tubing shapes. Guill's new reciprocating head eliminates an entire assembly operation. It also eliminates in-process inventory. Thus, there is no need for storage of various tubing shapes and connectors needed for assembly, fulfillment of orders and replenishment of finished goods.

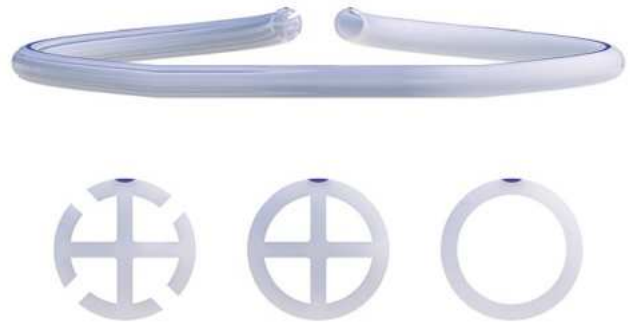
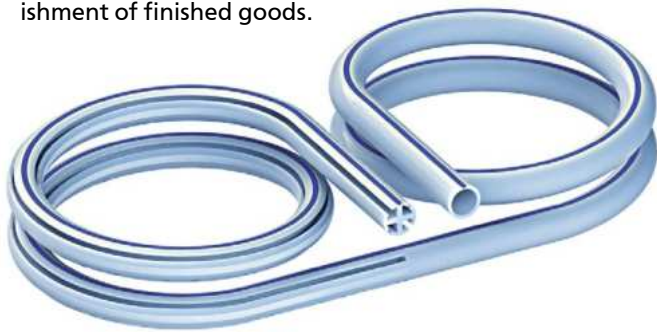

Furthermore, the reciprocating head eliminates a connecting piece, allows JIT production and products made-to-order. Lastly, it reduces total run time from receiving the order to shipping.

Such tubing is typically used in wound drain operations and other medical applications.

Guill Tool & Engineering
 Marcure, Senior Design Engineer
 jmarcure@guill.com

Peter Leary, Technical Sales Engineer,
 Extrusion Division
 pleary@guill.com



Co-Rotating Twin-Screw Technology for Compounding, Recycling and Direct Extrusion systems

Advanced polymer processing systems from lab to industrial production

- › **Compounding & Masterbatch**
- › High-efficiency **Recycling & Up-cycling**
- › **Direct extrusion** for high-tech foils and sheets
- ›› **Test your formulations at our INNOVATION HUB**



Still a people-driven company, easy to talk to, built on engineering expertise

MEET ICMA IN 2026

- › Chinaplas - China
- › PRS Europe - Netherlands
- › PLAST Milan - Italy
- › FAKUMA - Germany

› Scan for Full List ›



www.icmasg.com



SPE's ANTEC® to Drive Technical Education at NPE2027 as Part of Integrated Expo+ Education Experience

The Plastics Industry Association (PLASTICS) announced that the technical education program for NPE2027 will be powered by ANTEC®, the Society of Plastics Engineers (SPE) annual technical conference. The ANTEC® technical tracks, combined with other education sessions, will be presented as part of the Expo+ experience at the NPE2027 trade show.

This integration brings ANTEC's® rigorously curated technical content directly into the broader NPE program for the first time. As part of the Expo+ experience, ANTEC® programming will be included with Expo+ registration, creating a unified platform that combines technical depth with large-scale industry engagement.

The collaboration reflects the combined capabilities of PLASTICS and SPE following their recent merger and is designed to strengthen the connection between technical knowledge and commercial applications across the plastics value chain.

"When we said these organizations are better together, this is exactly the kind of collaboration we had in mind," said Matt Seaholm, President & CEO of PLASTICS. "By integrating ANTEC into NPE2027, we're bringing the industry's leading technical expertise directly onto its largest global stage – connecting research, innovation, and real-

world application in one place. This is a natural culmination of these two organizations coming together and represents a meaningful step forward in how we serve the plastics community."

For NPE attendees, the addition of ANTEC® provides access to in-depth technical content aligned with the innovations on display across the show floor. Topics will include areas such as AI-enabled processing, advanced recycling, sustainability, bioplastics, injection molding, additive manufacturing, polymer analysis, design, and materials performance – offering practical insight into current technologies and emerging developments.

For ANTEC® attendees and the SPE community, integration into NPE expands the reach and visibility of technical work by connecting researchers, engineers, and scientists with a broader, global audience that includes manufacturers, brand owners, and decision-makers.

"ANTEC® is the annual event for sharing cutting-edge technical information," said Patrick Farrey, Executive Vice President and Chief Integration Officer, PLASTICS. "Bringing ANTEC® to NPE2027 connects that learning with the full scale of the global plastics market where it can have the greatest impact."

In addition to ANTEC's® technical programming, the Expo+ educa-



Matt Seaholm

tion experience will feature sessions focused on sustainability, regulatory developments, workforce considerations, and business strategy, curated by PLASTICS. Together, the combined programming is intended to provide a comprehensive view of the challenges and opportunities impacting the plastics industry. An ANTEC® Call for Speakers will be announced shortly.

NPE2027, taking place May 3-7, 2027, in Orlando, FL, brings together stakeholders from across the global plastics industry to explore innovation, address current operational challenges, and identify strategies for future growth.

► www.plasticsindustry.org

American Foundation for a New Fund

Teknor Apex Company announced it has joined as a founding partner in a new €75 million investment fund with OSS Ventures to scale proven industrial software companies across North America and Europe.

Building Software Where It Matters: On the Manufacturing Floor

For Teknor Apex, this partnership reflects a shared belief: indus-

trial software only drives lasting change when it's built from the manufacturing floor up – alongside the operators, supervisors, and engineers who use it daily. That belief aligned the company with OSS Ventures, a venture studio founded in 2019 by Renan Devillieres that builds next-generation industrial software at the intersection of software development and manufacturing operations.

Teknor Apex will serve as the regional industrial anchor partner as OSS Ventures extends its operations into North America with a new office in Boston, MA – becoming the first U.S. manufacturer to both invest in and operate OSS portfolio software at scale.

"Manufacturing in the U.S. must become more competitive – and we believe we have a clear path to help make that happen," said Donald Wiseman, CEO, Teknor Apex.

“By combining real production environments, practical software, and the people who run our plants every day, we’re building a model for how industrial companies can scale technology in a way that actually works.”

Teknor Apex: From Co-Builder to Co-Investor

This partnership started on the factory floor. Teknor Apex and OSS Ventures began working together on venture building and investment activities across the U.S. and Europe. As that relationship deepened, Teknor Apex – a 100-year-old material science company that’s continually evolving – did something most corporate investors don’t: they ran the software themselves.

The company launched a multi-site digital transformation program across its own manufacturing operations – deploying OSS portfolio software to strengthen workforce enablement, operational visibility, and cross-site collaboration. What Teknor Apex found confirmed what OSS Ventures had built its model around: software designed on the factory floor performs differently than software designed for it.

Teknor Apex deployed three of OSS Ventures’ portfolio companies in their Rhode Island and Tennessee sites. The impact was immediate:

- **Oplit** allows Teknor Apex to set their plants up for success through a reduction in changeovers, improved yield, and a stronger foundation for more automated planning over time.

- **Fabriq** helps to strengthen a culture of continuous improvement, with problem-solving embedded at every level of the manufacturing organization.

- **Mercateam** supports operators, mechanics, and lab technicians in building critical skills and advancing their careers - helping Teknor Apex better invest in and make the most of its most valuable resource: its people.



This momentum has now led to a deeper, dual-track partnership. Teknor Apex and OSS Ventures are aligned as both core business partners and venture partners - with Teknor Apex joining as a founding partner in the €75M amplification fund alongside Decathlon PULSE and Groupe Peugeot Frères. The aim: help manufacturers scale effectively, accelerate reshoring and American manufacturing competitiveness, and digitize legacy operations with practical, deployable software.

“As we shape our next 100 years of manufacturing, digital transformation is the sole viable path to not only short-term efficiency, but long-term competitiveness,” said Michael Roberts, CIO, Teknor Apex. “By giving industrial software companies access to live production environments – with all the complexity and constraint that entails – this partnership creates the conditions for software that actually scales and empowers our people and our plants to work even more efficiently.”

The Mandate for U.S. Manufacturing

Teknor Apex recognizes that manufacturers in the U.S. face a clear mandate to modernize in order to reshore production and rebuild a resilient domestic supply chain. Upgrading plants and digital systems is essential to producing competitively, and safeguarding against the

From co-builders to co-investors: OSS Ventures’ Founder/CEO Renan Devillieres and Michael Roberts, CIO of Teknor Apex

volatility that has defined global manufacturing. At the same time, industrial software companies can only scale credibly when they work with real plants that expose them to the complexity and constraints of actual production.

Across its own manufacturing network, Teknor Apex has seen that the right software can do more than enhance operations - it can broaden what a manufacturer is able to achieve. The company views this initiative as an important step in advancing its own digital capabilities and helping shape a clearer path for manufacturers seeking to become more connected, agile, and capable industrial partners. For Teknor Apex, this kind of progress is accelerated by partnering with OSS Ventures – an organization that shares its values, understands the realities of production, and is committed to delivering practical, long-term solutions.

A company that has advanced through a century of industrial shifts is now betting on software as the next one – and building the infrastructure to prove it.

Teknor Apex Company
www.teknorapex.com

OSS Ventures
www.oss.ventures

New Americas Test & Training Center Opened

Global leader in sensor-based sorting solutions, TOMRA Recycling, has marked a new era of customer support for recyclers in the Americas with the opening of its new Americas Test & Training Center in Charlotte, North Carolina. The facility features a testing circuit equipped with the latest sorting technologies, a dedicated warehouse for critical parts storage and extensive training facilities.

“The expansion of our testing, training and warehouse space at our Americas headquarters reflects a commitment to continuously investing in growing markets and getting closer to our customers,” said Lars Enge, EVP and Head of TOMRA Recycling. “We are providing far more than just increased material testing capabilities. From pre-sale consultation and machinery installation to after-sales support and ongoing technical training, TOMRA Recycling partners with our customers throughout the equipment's full lifecycle to ensure long-term, optimal plant performance.”

Latest technologies

TOMRA Recycling's new 425 sq m dedicated Test & Training Center is equipped with the company's latest sorting technologies, providing customers in the region with a facility to test waste and plastic materials. It features the latest generation AUTOSORT™ equipped with TOMRA's deep learning AI technology, GAINnext™.

AUTOSORT™ combines a variety of features in a single machine with a flexible sensor configuration to meet the challenges of a dynamic market landscape, from municipal solid waste and paper to plastics and packaging. GAINnext™ leverages AI-based visual classification to identify hard-to-classify objects, maximizing recyclate recovery and purity levels.

For advanced testing of plastic flake materials, the new facility also includes AUTOSORT™ FLAKE and INNOSORT™ FLAKE technologies. The flexible INNOSORT™ FLAKE delivers simultaneous detection of polymers and colors, using an advanced near-infrared (NIR) spectrometer and dual-sided imaging with high-resolution cameras to sort high-purity flakes from contaminated mixed streams.

The facility in Charlotte features TOMRA's cutting-edge waste and plastic sorting systems



Michelle Landon: “Our customers can now enjoy expanded testing capacities, shorter lead times and greater flexibility”

AUTOSORT™ FLAKE offers a powerful combination of NIR spectrometer, full color camera and metal sensor to deliver exceptional performance for high-purity end products.

Providing end-to-end material tracking, the Waste Analyzer from PolyPerception – included in the circuit – harnesses the power of deep learning AI. Color cameras capture real-time images of material flow at strategic points in the line to analyze key performance metrics, such as throughput, waste composition and yield loss. Bringing transparency to operations, the real-time monitoring provided by the Analyzer increases performance and lowers costs through actionable data.

“Our customers based in the Americas can now enjoy expanded testing capacities, shorter lead times and greater flexibility when it comes to scheduling tests,” said Michelle Landon, SVP and Head of Americas for TOMRA Recycling. “Recycling operations are benefiting

Part of the new center are the deep learning solution GAINnext™ and the PolyPerception Analyzer



from collective global TOMRA expertise with our new Test & Training Center, since our Research & Development teams are continuing to innovate with new optical sorting and deep learning AI applications to meet customer needs.”

Expanded training and global reach

The new center has enabled TOMRA to expand and enhance its training capabilities at its Americas headquarters. In addition to customer maintenance and performance training, TOMRA’s service technicians will also undertake training at the new facility.

Two one-day customer training programs have already been announced. Operational Maintenance Training teaches customers basic machine operation and safety, performance data back-up and system restoration, preventative maintenance measures and fault code diagnostics. TOMRA’s new Maximizing Performance Training overviews advanced settings machine operation, understanding machine performance, stabilizing and improving performance and diagnosing machine conditioning.

Highlighting the strategic importance of the new Test & Training Center, Ralph Uepping, Head of Technology for TOMRA Recycling, said: “The Charlotte facility is a significant addition to our global network, serving as one of seven TOMRA Test & Training Centers worldwide. By mirroring the high standards set at our sites



During the official opening event, guests experienced live demonstrations and examined various test results

across Europa and Asia, the center ensures that recyclers in the Americas have direct access to the same level of technical expertise and innovation found anywhere in the world. We invite all recyclers to bring their materials and sorting challenges to TOMRA to develop a flexible, customized solution that maximizes throughput, yield, purity and profitability.”

TOMRA
www.tomra.com

**Strategic Partnership –
 Memorandum of Understanding Signed**

interpack, the leading international trade fair for processing and packaging, and PMMI, The Association for Packaging and Processing Technologies, have signed a Memorandum of Understanding (MoU) during interpack 2026, marking a new step in strengthening collaboration between the global and North American packaging industries.

The agreement is designed to expand international engagement, strengthen connections between Europe and North America, and create new opportunities for companies across both markets. It also reinforces interpack’s role as a key global platform for North American companies looking to grow their international business.

A central element of the collaboration is the North American Pavilion at interpack 2029, which will be organized and managed by PMMI. The pavilion will provide North American exhibitors with a unified presence and increased visibility at one of the industry’s most important international events.

“For many years, PMMI and interpack have maintained a close and trusted dialogue that we highly value. This agreement is a natural next step to further develop that exchange and expand international connectivity for the benefit of our shared customers”, says Thomas Dohse, Director of interpack.



„PMMI is excited to have this opportunity to bring our members to this important industry event. We appreciate interpack’s willingness to work with PMMI to make this happen and expect this effort to be a major success for our members “, says Jim Pittas, President & CEO of PMMI.

With this partnership, interpack and PMMI are reinforcing their shared commitment to drive innovation, expand global exchange, and advance sustainable solutions across the processing and packaging industry.

Messe Düsseldorf GmbH
www.interpack.com

Operation Clean Sweep® Releases 2025 Global Impact Report Highlighting Industry Progress

„Operation Clean Sweep® (OCS)“, a globally recognized resin stewardship program jointly administered by the Plastics Industry Association (PLASTICS) and the American Chemistry Council (ACC)'s Plastics Division, released its 2025 Global Impact Report, highlighting industry-wide progress to prevent plastic resin loss and keep materials out of the environment. The report underscores the continued growth and impact of OCS as a global, industry-led stewardship program focused on minimizing plastic pellet, flake, and powder loss across the value chain.

OCS is active in more than 60 countries and brings together companies across the supply chain – from material suppliers and processors to logistics and transportation providers – to implement tested strategies that prevent plastic resin loss while also strengthening operational performance.

The annual Global Impact Report highlights continued international growth and expanded adoption of enhanced program elements, includ-

ing OCS Data Reporting and Verification—advancing transparency and supporting facilities in working toward the goal of zero resin loss through independently verified OCS management practices.

Key highlights from the 2025 OCS Global Impact Report include:

- More than 6,000 companies worldwide participate in OCS
- More than 300 external inspections were conducted across International OCS Programs in 2025
- The logistics sector saw the fastest membership growth, reinforcing the importance of resin handling and loss prevention across the full supply chain
- OCS members represent over 65% of U.S. plastic resin production capacity
- U.S.-based OCS members trained more than 35,000 workers on zero resin loss and prevention strategies

“The plastics industry understands the importance of preventing plastic pellet loss and OCS continues to lead in advancing responsible envi-

ronmental stewardship,” said Patrick Krieger, PLASTICS Senior Vice President of Sustainability and Policy. “The 2025 OCS Global Impact Report highlights how resin loss prevention is being implemented worldwide, with growing participation across the supply chain demonstrating that real progress depends on coordinated, collaborative action.”

“OCS reflects our industry's shared commitment to responsible resin handling at every stage of production and transport,” said Adam Peer, senior director of Plastics Packaging at the American Chemistry Council. “With the majority of U.S. resin production capacity represented by OCS members, and independent verification strengthening the program, we are turning the goal of zero resin loss into everyday practice.”

To read the 2025 OCS Global Impact Report:
opcleansweep.org/about/global-impact-report-2025/

➔ plasticsindustry.org

New Analysis Examines Shifting U.S.-Japan Trade Dynamics Amid Rising Tariffs and Global Uncertainty

The Plastics Industry Association (PLASTICS) Chief Economist, Dr. Perc Pineda, has released a new economic analysis exploring how recent changes in U.S. trade policy are reshaping global plastics trade – framed through a cross-border conversation with international trade expert Professor Shujiro Urata.

The analysis examines the evolving U.S.-Japan trade relationship against a backdrop of higher tariffs, shifting supply chains, and increased global economic uncertainty. New data show U.S. plastics trade declined in 2025, while import duties surged – signaling a more complex trade environment driven by rising costs and changing sourcing decisions.

Dr. Pineda writes, “While the smaller trade deficit may appear positive on the surface, the data suggest a more complex picture – one shaped by reduced trade flows, higher costs, and shifting sourcing decisions rather than stronger underlying competitiveness. The broader global trade environment has shifted, forcing countries to reassess commercial relationships as supply chains adapt to new tariffs, geopolitical risks, and slower global growth. For the plastics industry, that means the U.S.-Japan trade relationship is no longer just about bilateral flows – it is increasingly about resilience, competitiveness, and strategic alignment in a changing global economy.”



Dr. Perc Pineda

The conversation also explores how changes in exchange rates, investment trends, industrial policy, and consumer demand are influencing global trade and supply chain alignment.

➔ www.plasticsindustry.org

The American National Standards Institute (ANSI) Announced as an Official Partner for World Engineering Day for Sustainable Development 2026

ANSI has been selected as an official partner for World Engineering Day for Sustainable Development (WED) 2026, an annual initiative highlighting the essential role that engineers and engineering play around the world.

ANSI brings together industry, government, academia, and other stakeholders to shape standards that make technologies safer, more reliable, and interoperable. Representing the United States in leading international standards bodies, ANSI helps advance sustainable development on a global scale.

“World Engineering Day is a powerful reminder that the solutions to our greatest global challenges depend on collaboration across borders, disciplines, and sectors,” said ANSI president and CEO Dr. Laurie E. Locascio. “Engineering and standards go hand-in-hand, and both are essential to building a sustainable future. ANSI is proud to be an official partner for WED 2026, and we look forward to highlighting how standards help turn engineering innovation into real-world impact.”

World Engineering Day launched in Jakarta, Indonesia, on 4 March 2026, marking the start of a year-long campaign of events, films, features and news. The focus of this year’s theme is “Smart engineering for a sustainable future through innovation and digitalisation.”

An official International Day, as proclaimed by UNESCO, WED is operated by the World Federation of Engineering Organisations (WFEO), the global body that spans members from more than 100 countries and represents over 30 million engineers worldwide.

WED 2026 provides governments, UN-associated organisations, policymakers, educators and leaders in the public and private sectors with the opportunity to raise awareness of the importance of engineering. All campaign content is produced by SJH Studios – the official media partner and broadcaster for WED – and hosted



The American National Standards Institute (ANSI) announced as an official partner for World Engineering Day for Sustainable Development 2026

on the official WED website at www.worldengineeringday.net.

Seng-Chuan Tan, President of the WFEO, says: “World Engineering Day brings together engineers, governments, academia, industries and individuals to exchange ideas, drive innovation and take meaningful action. Collaboration is essential – we must work together to transform innovative ideas into real-world impact. When we bring together different voices, perspectives and expertise, we create stronger, more sustainable solutions.”

Stephen Van Der Merwe, SJH Group Director, Licensing, Legal and Contracts, says: “ANSI is committed to international standardisation for global progress, and we’re thrilled to have them on board as an official partner for this year’s World Engineering Day campaign.”

➡ <https://worldengineeringday.net/>

Polystyrene Recycling Alliance Partners with Mexican Plastics Pact to promote High-Impact Polystyrene Circularity

The Polystyrene Recycling Alliance (PSRA), a leading North American coalition developing innovative polystyrene recycling solutions, announced a strategic collaboration with the Mexican Plastics Pact (PPMX) to create the conditions needed for collecting and recycling high-impact polystyrene (HIPS) dairy packaging throughout central Mexico.

This pioneering initiative represents a coordinated effort to establish economically viable circular systems for polystyrene materials, addressing post-consumer recovery gaps while demonstrating how HIPS, in particular, can be effectively integrated into aligned collection, processing, and end-market frameworks.

The partnership brings together leading consumer brands, including Danone, Lala, and Yakult, alongside specialized recycling networks, such as Ecolana and Grupo Mexico Recicla, to create an integrated value chain that transforms discarded dairy containers into high-quality recycled resin for new applications. Through targeted support from PSRA, the initiative will establish collection operations spanning Mexico City, the State of Mexico, Querétaro, and Puebla, channeling recovered HIPS through Resirene’s U.S. Food and Drug Administration (FDA)-compliant recycling processing facility.

What distinguishes this collaboration is its market-driven approach to understand and strengthen recovery

systems. While HIPS is widely utilized in Mexican dairy packaging due to its adequate performance characteristics, recovery rates have been limited by fragmented infrastructure and unpredictable end-market demand. The partnership addresses these systemic challenges by promoting forward-looking commitments from participating brands, creating the economic certainty necessary for sustainable investment in collection and processing capacity.

"We want to thank the Mexican Plastics Pact for partnering with us on this important, circular initiative," said Justin Riney, Chair of the Polystyrene Recycling Alliance. "Circularity depends on system alignment – not material substitution. When collection, processing, and market demand are coordinated, polystyrene can continue delivering value within a modern circular economy. The framework being established here offers insights that are relevant well beyond a single market."

"Accelerating circularity requires the collaboration of all actors of the value chain to ensure that the materials complete the loop," said Lisseth Cordero, Member of the PPMX and CEO of ECOLANA. "This partnership allows us to strengthen the system around high impact polystyrene – testing practical solutions, generating real-world insights, and demonstrating how collaboration across the value chain can advance broader circularity goals in Mexico."

The Mexican Plastics Pact, operating as part of a global network of thirteen national initiatives focused on plastic pollution reduction, provides essential coordination among businesses, government agencies, academic institutions, and civil society organizations. This collaborative framework enables the development of comprehensive solutions that integrate technical innovation, logistical optimization, and market development to establish practical insights on improving recovery systems for currently challenging plastic packaging formats.

Over a 14-month implementation timeline, the partnership will validate collection methodologies, demonstrate processing capabilities, formalize brand agreements, and develop enhanced design guidelines to improve recyclability. The results will provide data-driven insights into recovery performance, processing economics, and value chain alignment that can inform broader regional packaging circularity strategies.

Together, PSRA and PPMX are establishing a scalable framework for strengthening high-impact polystyrene recovery systems – supporting durable, market-based circularity solutions across Latin America and informing broader North American efforts to integrate this material into sustainable packaging systems.

Polystyrene Recycling Alliance (PSRA)
www.PSRRecycling.org

New Recycling is Real Video Released

The Plastics Industry Association (PLASTICS) released a new video as part of its Recycling is Real advocacy initiative, spotlighting recycling operations at Dow and Circulus facilities in Arab, Alabama, and Ardmore, Oklahoma. The video highlights the work taking place inside these facilities – where used plastics are sorted, processed, and transformed into materials that can be used again in manufacturing.

Since launching in 2023, PLASTICS' Recycling is Real campaign has produced 23 videos featuring both mechanical and advanced recycling facilities nationwide. Each video centers on the people behind the process – the dedicated employees whose work supports recycling systems in communities across the country.

"At companies like Dow and Circulus, you see circularity in action – from processing materials to preparing them for reuse across the supply chain," said Matt Seaholm, President and CEO of the Plastics Industry Association (PLASTICS). "Recycling is Real brings that work

to the forefront, showing how people, technology, and infrastructure come together to keep materials in use and support a more circular economy."

"We believe it takes a materials ecosystem to help reduce plastic waste and create a circular economy," said Ahmad Kawas, North America Commercial Vice President of Dow's Packaging and Specialty Plastics business. "Bringing together value chain partners from collection, design, manufacturing and the end consumer allows us to unlock the value of plastic. And that is what we are doing by combining Dow's materials science expertise with Circulus' film recycling technology to expand the circular offerings we are generating for customers."

The Recycling is Real campaign provides educational content to help elected officials and policymakers better understand recycling's role as a critical link in the circular economy. By showcasing real facilities and the people behind them, the initiative offers a firsthand look



at where and how recycling occurs across the country – highlighting the technologies, processes, and workforce driving progress, while underscoring the importance of continued investment in U.S. recycling infrastructure.

Previous featured locations include Atlanta, Georgia; Kingsport, Tennessee; Madison, Wisconsin; North Vernon, Indiana; Baton Rouge, Louisiana; Portland, Pennsylvania; Eagle Rock and Wytheville, Virginia; Rialto and Chino, California; Piqua and Ironton, Ohio; Reidsville, North Carolina; Tampa, Florida; Houston, Texas; Farmingdale, New York; Hilliard, Ohio; Plymouth, Michigan; Reading, Pennsylvania; and Eugene, Oregon.

Dow
www.dow.com
Plastics Industry Association (PLASTICS)
www.plasticsindustry.org

EXTRUSION

EXPERT MAGAZINE ON PLASTICS EXTRUSION

The only technical magazine worldwide exclusively for the sectors:

- Material Preparation
- Compounding
- Extrusion
- Recycling
- Calendering
- Thermoforming
- Welding
- Finishing of Plastics and Elastomers



Extrusion (German)

Extrusion International (English)

Extrusion International USA (English)

Extrusion Asia Edition (Mandarin/English)

The only plastics trade magazine for Asia, published from Germany

8 issues a year

6 issues a year

6 issues a year

2 issues a year

EXTRUSION
GLOBAL

All editions available for free:

www.extrusion-global.com

VM Verlag GmbH Cologne/Germany



Technology Partnership for the Spanish Market

PiXARGUS has taken a new strategic step to grow in the European plastics and rubber market by expanding its sales network on the Iberian Peninsula. Newly on board as sales representative is Comercial Douma – a technology service provider with in-depth knowledge of the extrusion industry and a strong network across Spain.

As a family-owned company in its third generation, Comercial Douma has nearly 40 years of experience in plastics and rubber extrusion. The technology service provider, based in Barcelona, specializes in innovative solutions for clients in the mechanical engineering industry and represents leading international companies and brands in the Spanish market. Its portfolio includes renowned manufacturers, such as iNOEX, Battenfeld-Cincinnati and Exelliq. With the new ProfilControl 7 XLine series of smart inline systems for profile inspection and the highly versatile AllRoundDia inspection system for tubes and hoses, Comercial Douma's range for quality control in extrusion processes now also includes the advanced, future-oriented optical inspection solutions by PiXARGUS.

Excellent consulting and comprehensive on-site service

PiXARGUS customers across Spain can now directly turn to a highly proficient team of experts, consisting of six sales managers and a dedicated technical support team, all with profound industry and process knowledge and

ProfilControl 7 PlastX is the perfect solution for standard applications in plastic profile extrusion and is optimally designed for inspection tasks with 4 to 6 cameras. The specially tuned precision optics enable accurate inline inspection of surface defects and/or dimensional deviations. Perfectly engineered for the demands of plastic extrusion – intelligent and flexible, without unnecessary complexity



A strong team celebrating a new partnership: PiXARGUS sales specialist Luc Despineux (2nd from left), and CEO Sergio Douma, COO Rudy Douma and Erik Douma, Sales + Technical Service

extensive practical experience. "Our customers will benefit from the local sales support, close customer relations and customized on-site service," says Luc Despineux, international sales specialist at PiXARGUS.

Designing the future of extrusion with expertise of the CiTEX group

As specialists in intelligent inline inspection systems, PiXARGUS is the third strong player within the CiTEX group represented by Comercial Douma – together with iNOEX, experts in x-ray and radar-based measuring systems for round products with a focus on tube wall measurements, and iBA, suppliers of turnkey extrusion lines for PEX-a pipes. Technology service provider CiTEX has thus created a powerful network for customers on the Iberian Peninsula seeking future-oriented sensor and measuring technology for extrusion lines and comprehensive solutions from a single source.

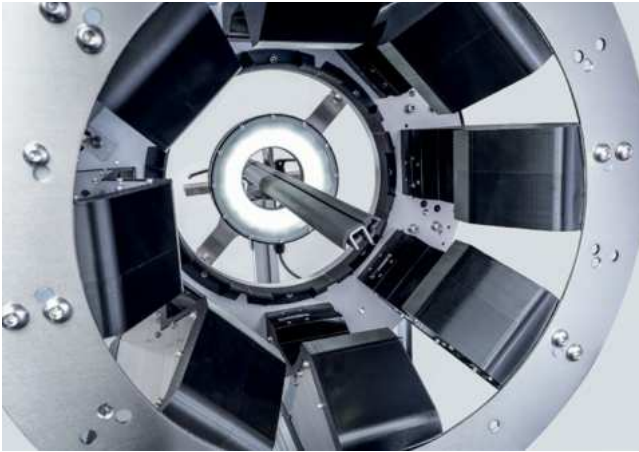

ProfilControl 7 RubberFlex is the powerful system configuration for standard rubber profile applications. The system is flexibly configurable with up to 8 cameras and integrates high-performance optics with advanced software functionalities. Developed for the highest precision in dynamic production environments, this smart defect detector ensures maximum inspection performance for elastic, variable, and filigree rubber profile

Impressive touchdown at the Equiplast 2026: PiXARGUS and Comercial Douma presented the the new smart inline inspection series ProfilControl 7 XLine

Equiplast 2026 in Barcelona, the leading trade show on the Iberian Peninsula for the plastics industry, was actually a home game for Comercial Douma. Customers and visitors to the trade show had the opportunity to experience live the new high performers of PiXARGUS' smart XLine series and the new strong partnership between PiXARGUS and Comercial Douma. The new partners set new standards in the extrusion industry in terms of quality, efficiency and digitalization.

Efficiency boost in quality control: The smart inline inspection series ProfilControl 7 XLine

Not more software than necessary, and as little hardware as possible: With its new inline inspection series, ProfilControl 7 XLine, PiXARGUS is launching an entirely new system approach. Efficiency is now the ace, precision the key. The new, modular sensor head design dispenses with a complete housing and a hinged cover. The open sensor plate with a predefined hole pattern makes it possible to position the cameras in a highly flexible way – according to the sector-specific setup. Up to 700 high-performance LEDs produce a homogeneous illumination field with maximal light yield. The system's intelligent software is key in making ProfilControl 7 XLine a high-performer. It forms the basis for the intuitive operation of the system and the time-saving automated inspection processes.

ProfilControl 7 PlastX for plastic extrusion: This powerful inspection system for plastic profiles combines best performance with outstanding cost efficiency – features that make it the system of choice particularly in the win-



With its new inline inspection series, ProfilControl 7 XLine, PiXARGUS is launching an entirely new system approach. Efficiency is now the ace, precision the key. The open sensor plate with a predefined hole pattern makes it possible to position the cameras in a highly flexible way – according to the sector-specific setup. The system's intelligent software is key in making ProfilControl 7 XLine a high-performer

down construction industry. The complete, all-round inspection process ensures the reliable detection even of the smallest surface defects and geometrical deviations, thus making an important contribution to the reduction of scrap and process costs. For the secure detection of grooves, a special software module has been integrated. In its basic version, ProfilControl 7 PlastX needs only 4 cameras. This has been made possible by smartly combining optimized optics with high-performance camera elements, which can be expanded to 6 cameras with an adapted positioning to include the clamping dimensions for window installations.

ProfilControl 7 RubberFlex for rubber extrusion: This defect detector for rubber profiles is ready to cope with the highly exacting quality requirements of the automotive industry. It handles quality control of elastic, variable and filigree rubber profiles of simple and medium complexity with ease. The modular sensor head is freely configurable with up to 8 highly specialized cameras. The flexible positioning of the cameras enables the continuous and complete capturing of all areas of the profiles that will later be visible. Deformations have no chance, perfect dimensional accuracy is guaranteed – with this attractively priced system.

PiXARGUS GmbH
A CiTEX Group Company
Monnetstr. 2, 52146 Würselen, Germany
► www.pixargus.com

Introducing New AI-Driven SIMAC® Surface Testing System

Zumbach Electronic is advancing surface inspection technology with the launch of the next-generation SIMAC® Surface Testing System, now empowered by AI-driven Intelligence. Designed for cables, tubes and hoses, the new SIMAC® solution delivers a breakthrough in accuracy, adaptability and on-line quality assurance. Built on deep-learning innovation, the system moves beyond traditional defect detection to provide manufacturers with actionable insights, continuous learning capabilities and an unprecedented level of process transparency.

On-line detection: Identifying defects at full production speed

At the core of the new SIMAC® platform is its artificial intelligence-based high-performance detection engine, developed to recognise surface abnormalities instantly and reliably, with the following benefits:

- Detects surface defects inline at full production speed
- Requires no defect labelling, because it is trained entirely on defect-free images
- Provides adaptive behaviour, automatically compensating for process drift
- Allows fast model recalibration for new production conditions
- Includes adjustable sensitivity, enabling a configurable precision/recall balance depending on customer requirements

This means that operators no longer need to manually tune thresholds or define defect rules. Instead, the deep-learning engine continuously evaluates the product surface, flagging any deviations from expected patterns.

Intelligent classification: Knowing exactly what is wrong

Detection is only the first step. With SIMAC®'s new intelligent classification module, users also gain clarity about what type of defect has occurred. The system can:

- Automatically assign defects to predefined types
- Provide precise defect localisation on the product
- Support the introduction of new defect types, when combined with model retraining
- Offer adjustable sensitivity for enhanced precision or broader coverage
- Apply a "one-for-all" model, meaning a single trained model can serve multiple products

This unique AI-driven defect classification tells us exactly what is wrong, enabling engineers to better un-



derstand production issues rather than just reacting to alarms.

Continuous improvement: A system that evolves with production

One of the most forward-looking capabilities of the new SIMAC® is its ability to evolve. The system's continuous improvement framework allows it to become increasingly accurate, consistent and adapted over time.

Key features include:

- Fast recalibration of the detection model
- Re-classification and correction of mis-detected defects
- Incremental enrichment of training datasets
- Full retraining when introducing new defect categories
- Ongoing optimisation of thresholds and system behaviour

Because the new SIMAC® is not based on fixed rules, it evolves with production, positioning itself as a future-proof solution that grows alongside customer processes, raw materials and quality requirements.

Advanced process analysis: Turning data into insights

Beyond detection and classification, the SIMAC® introduces a powerful process analysis module that helps manufacturers understand not only what defects occur, but why. The module offers:

- Statistical monitoring of defect frequency and distribution
- Trend analysis over production length and time
- Correlation between defect type and position
- Identification of periodic or localised patterns
- Filtering of non-critical defects based on type

With these capabilities, factories can trace recurring issues back to root causes, such as tooling wear, material inconsistencies or periodic mechanical vibration. The provision of filtering and statistical visualisations highlight how operators can quickly isolate relevant defect categories.

From detection to decision, instantly

The combination of AI-based detection, intelligent classification, continuous learning and deep process insights transforms SIMAC® from a traditional inspection tool into a comprehensive decision-support system.



Operators can react faster, engineers can analyse more effectively and production managers gain reliable data for optimising output quality.

Zumbach's next-generation SIMAC® Surface Testing System sets a new benchmark for the industry: smarter detection, deeper understanding and adaptive performance that keeps pace with the dynamic environment of wire, cable, tube and hose manufacturing.

ZUMBACH Electronic AG
P.O. Box CH-2552 Orpund, Switzerland
sales@zumbach.ch, www.zumbach.com

Polyketone Pipe Extrusion

Polyketone (PK) is primarily used in pipe applications where high chemical resistance, mechanical toughness, and excellent barrier properties are required. It often serves as a high-performance alternative to materials such as PA12 or POM.

Automotive Industry & Fuel Systems: Due to its extremely low permeability to fuels and high resistance to aggressive chemicals, PK is frequently used for fuel lines.

Chemical Plant Engineering: Polyketone pipes and lines are ideally suited for transporting aggressive media, as the material exhibits excellent hydrolysis resistance and is insensitive to many solvents.

Industrial supply lines: PK pipes offer high impact strength and fatigue resistance, making them suitable for durable industrial components and pressure lines.

Polyketone is a thermoplastic with special properties. Processing via extrusion requires certain specific features in the design of the extruders and in the handling procedures during the start and end of the extrusion process.

Processing Considerations

Minimal shear stress, short residence times in the extruder, no mixing sections or if necessary, those designed for optimal flow, no use of screens or breaker plates, no use of melt pumps. Incorrect processing leads to discoloration, cross-linking and inhomogeneous melt



There is a manufacturer of polyketone that recommends a very simple extrusion concept based on a smooth feed bush intake and a simple 5-zone screw. This concept has the disadvantage of low output per machine size, and likely also fluctuations in output due to the pre-heated material and the unstable feed through the feed zone. The specific characteristics and requirements described above are therefore difficult to meet.

Specification and special criterias for PK extrusion	Alternativ supplier	CONEXTRU
Extruder diameter, mm	90	45
L/D	30	30
Barrel heating zones	4 heating cooling	4 heating cooling stronger heaters
Intake design	Smooth 0,5 D long	Straight grooved 4,0 D long
Feed temperature °C	20	80
Target output kg/h	100	100
Spec. Energy of PK Wh/kg	350	350
Installed motor power kW	90	33
Circumference speed at output recomanded below 0,3 m/sec	0,4	0,2
Screw type	5 zone design	barrier type 22 D long barrier part
Mixing Elemnts	no recomanded	possible streamlined

Table 1: Extruder concept comparison

CONEXTRU – always applies the concept with a grooved feed section for technical polymers such as PA, ABS, PMMA, PC, EVOH, PVDF, PFA, MFA, ECTFE, and also for PK. The screw geometries for technical polymers so often recommended by raw material manufacturers, in combination with a smooth feed zone, primarily have the disadvantage of low feed rates, fluctuating feed behaviour, and non-linear feed behaviour across the speed range.

In contrast, there are the characteristics of the grooved feed zone. This grooved feed zone is available in CONEXTRU standard straight-grooved design – meaning there is no special groove shape or number compared to polyolefin processing of PE and PP. The difference lies solely in the temperature control. While polyolefins are processed with the feed bushing kept as cool as possible, these engineering polymers are processed with a heated feed bushing – because most plastics are preheated and enter the feed zone at a higher pellet temperature. However, the higher feed screw temperature also results in a slightly lower conveying capacity per revolution, thereby ensuring gentle, stable conveying of solid materials. A closed-loop system using silicone oil is employed for feed screw temperature control, allowing a temperature range between 20 and 250°C to be set depending on the material.

Grooved feed zones offer the advantage of absolutely stable feeding due to the nut-spindle effect. In more technical terms, this is due to the compression and friction between the grooved bushing and the material, as well as minimal friction between the screw base and the material. Furthermore, it has been shown that a barrier screw also offers advantages; there are numerous ways to design a barrier screw. One of the most influential parameters is the barrier gap and the length of the zone. This allows for gentle shearing over a long zone.

It is recommended to start the extruder with PP – using standard processing temperatures for PP and to switch to PK once the extruder and die are filled. If unmolten particles are visible, higher temperatures should be set. These can also be raised to up to 260 °C contrary to the raw material manufacturer's recommendation.

Run sheet of C 45 30 Extruder		
Material	HYOSUNG / POLYKETONE	
Type	M 730 R	
Extruder / max. RPM / kW	C 45 30 150 33	
max. Ampere Motor / max. RPM Motor	67 A / 1500 RPM	
type of feed bush	straight grooved	
Screw	intake, transmission, barrier part, short mixing	
Heating / Cooling Zone	set / actual	
Material Temperature after drying	°C	80
Feed bush	°C	100 100
E 1	°C	240 240
E 2	°C	230 230
E 3	°C	230 230
E 4	°C	220 220
Adapter	°C	220 220
Throttle Valve	°C	220 220
Speed Screw	RPM	80
Motor speed	RPM	793,6
Melt temperature in Adapter	°C	230
Melt temperature on floor	°C	225
Melt pressure Trothle valve	bar	266
Output manual	kg/h	100,0
Spec. Output	kg / RPM h	1,25
ENERGY MOTOR		
Electric current Motor	A	55
Load Motor calculated from Amp	%	82
Motor power	kW	27

Table 2: Extrusion protocol

It is important to ensure that no cross-linking or yellow discoloration occurs. These higher temperatures are possible and necessary because the residence time in grooved machines is significantly shorter than in smooth extruders for the same output. A short residence time prevents cross-linking. The extruder is shut down using the PP flushing process.

Outlook for PK in Pipe Extrusion

The growth of polyketone (PK) is skyrocketing as it evolves from a niche product into a genuine strategic alternative to established engineering plastics. Here are the key trends for the coming years. Annual growth is projected at approximately 5%. Another key factor in its success is its environmental profile, as its production uses carbon monoxide and does not contain free formaldehyde, unlike POM, for example.

The extrusion concept presented here, featuring a grooved feed section and a barrier screw, enables efficient processing and is also suitable for higher output rates through larger machine sizes.

By J. Dobrowsky

CONEXTRU GmbH
Klosterstasse 19, 3011 Irenental, Austria
Dobrowsky.j@conextru.eu

Getting the Most from Your Extrusion Tooling

Tooling maintenance improves extrusion efficiency, enhances quality and boosts overall productivity for your medical tubing applications.

By: Glen Guillemette,
President Guill Tool & Engineering

By utilizing state-of-the-art production equipment and processes, machining tolerances are held extremely close on today's multi-lumen and multi-layer medical tubing. It is important to note that any misalignment of the tools may be exaggerated in the final product output. Clean parts, especially with sealing and locating surfaces, are key to product performance and successful end products. These surfaces receive the most care and attention during manufacturing and are the control surfaces that ensure uniformity throughout the tubing. Remember, precision-machined alignments are affected by even a speck of dirt measuring only a few thousandths of an inch. A human hair is about 0.003" (0.08 mm), and since there are many such surfaces in a quality tool, cleanliness is critical.

Checking of the tools for any deformities is also important. Burrs, scratches and scrapes are usually a result of careless handling and/or storage of equipment. Double and triple-layer extrusion heads pose an even greater challenge for maintenance. The number of sealing and centering surfaces multiplies and can magnify the results of dirty tools. During changeovers, the head may be disassembled in order to change compounds and/or tips and dies. Foreign matter is usually introduced at this point and residual materials must be thoroughly removed. Physical tool damage often occurs during this phase, due to mishandling and poor storage techniques. These are highly precise parts, but can also be heavy and bulky to remove by hand.

Use of a dedicated work cart exclusively reserved and equipped for extruder head maintenance is recommended. This cart along with a supply of spare components and hardware is easily justified, especially when examining the potential cost savings that result from well-maintained tools. The following should be considered:

- 1.) Maintain a clean, organized work area with soft and clean renewable work surfaces
- 2.) Use a vise with soft jaws, such as copper
- 3.) Use special equipment, such as tip removal tools, etc.
- 4.) Standard tools include wrenches, soft-faced hammers, etc.
- 5.) Maintain a supply of soft, clean rags.
- 6.) Use cleaning solutions in spray bottle.
- 7.) Use spare parts as suggested by your tooling supplier, properly organized and stored.



8.) Keep handy your equipment's repair/maintenance manual.

9.) Have a small surface plate to provide a true flat surface.

10.) Use a set of appropriate gauge and tip pins for initial tool location adjustment.

11.) Make sure you have all the proper lifting aids available, including overhead hoists, hydraulic lifts, etc. In most situations, the head and tooling will still be at elevated temperatures, therefore lined gloves are needed when handling.

Today, tubing manufacturers compete with companies all over the world. To be a successful and profitable company, quality and efficiency are essential. This is especially true in extrusion, where material costs are usually much higher than labor costs. Like a racing car stuck in the pit, many extruders sit idle because of poor or damaged tooling, plus excess maintenance time. Overhead costs add up and losing money is the result. Some start up quickly and make scrap, whereas others start up and run a product oversized to hold minimum tolerance. They waste 10 to 20% of the material, which can run from 50 to 90% of the product cost. The tooling supplier goes to great lengths so that tips and dies are machined to a determined specification, ensuring perfect concentricity and alignment. The material is then distributed in the proper location as part of the finished product.

Understanding Maintenance Procedures: Get Organized Before You Start

Example 1: In this example, with an improperly centered tool, a calculated out-of-tolerance area of 0.059

in² (38 mm²) was derived. When the two surface areas were compared, the calculated material waste was 11.8% of the finished product. The formula is % wall = min. wall thickness, max. wall thickness X 100.

Example 2: Alternatively, if the % wall can be increased from 80 to 95%, a savings of about 12% of total cost can result. Savings will vary depending on the designs, of course.

Get help for heavy parts and awkward situations. Surfaces and edges are hard and therefore somewhat brittle, so dropping a part or striking parts together can result in damage. Store your tools properly in a dry, clean area – a dedicated spot for each tool is best. These areas should have soft surfaces and each instrument should be covered after cleaning. Also, tools should be segregated so that they do not come into contact with each other. And tools and all instruments should be cleaned thoroughly before storage.

For disassembly of tools, it is imperative to use purpose-built tooling to facilitate disassembly. These should be available from your supplier. If they are not, consult with a reputable tooling house for replacements. The cost of these tools is easily offset by potential damages, frequently caused by improper equipment such as hammers and drifts. Follow the guidelines outlined in your operator's manual. Individual tools may have specific recommendations, so contact your supplier if anything is unclear. Your supplier understands that optimum performance relies on proper care and maintenance. Here are some useful tips:

1.) Clean your equipment while it is still hot as the residue is easier to remove. It helps to remove and clean one piece of tooling at a time in order to maintain elevated temperatures.

2.) When cleaning a dual compound crosshead, (plastic and rubber) clean the plastic tooling first; the rubber second.

3.) Never use steel tools such as scrapers or screwdrivers because these can scratch and mar the tooling.

4.) Don't use open flames because this generates excessive heat especially in thin sections, which can affect hardness, concentricity and tolerances of components. Recommended cleaning tools and materials include:

a.) Brass pliers to grip material and aid in pulling

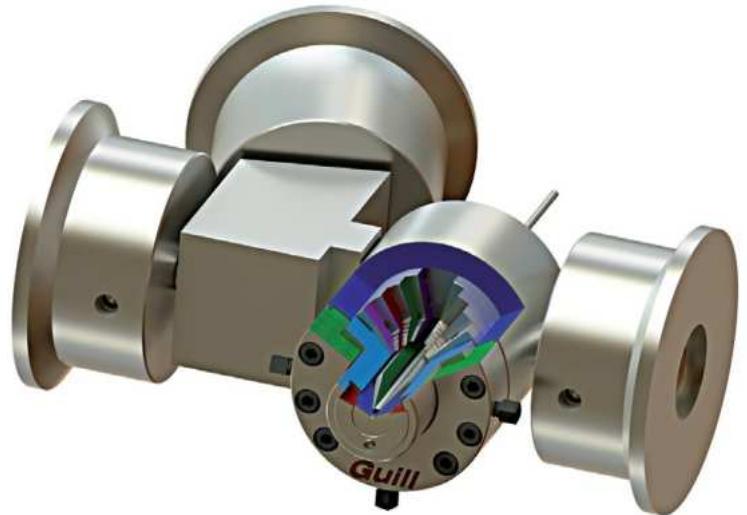

b.) Brass scrapers available in different widths for cleaning flat exposed surfaces

c.) Brass bristle tube brushes that are available in diameters from 1/16" to 1" in 1/16" increments (ideal for cleaning holes and recesses)

d.) Brass rods—different diameter rods are good for pushing material out of flow holes

e.) Copper gauze for cleaning and polishing exposed round or conical surfaces

f.) Copper knives for removing residue from recesses and other hard-to-reach areas. Also, polishing compound restores polished surfaces

g.) Compressed air, which is more effective for releasing plastic, but also aids in rubber removal. Be careful not to force debris into recesses with compressed air

h.) Cleaning solutions may be useful, so remember to use fresh, clean rags (used rags often have metal chips embedded in them, which may scratch polished surfaces)

i.) Cleaning oven – for plastic only. Follow manufacturer's recommendations. If no temperatures are specified do not exceed 850 degrees F (454 degrees C). Don't quench tooling to cool, as this could affect tooling hardness, concentricity and tolerances.

j.) Purging compounds – several are offered to purge the extruder screw/barrel of residual polymer and rubber compounds

Removing Excess Material for Optimum Machining Efficiency

Clean parts are critical to extrusion tooling performance and quality manufacturing. This is especially true for the sealing and locating surfaces – that control uniformity of the production process. For general maintenance of the tools, before storage or tooling change-over, a thorough cleaning and removal of the excess material assures the precision machining alignments required to produce end products to the precise tolerances. Equipment should be cleaned while it is still hot, since residual polymer and rubber will be easier to remove. Be sure to follow all MSDS recommendations when heating the tooling. Thermal gloves are used to protect the hands from the heated tooling surfaces. A brass scraper, as well as a brass or



copper wool cleaning cloth are recommended because they are soft enough not to scratch the surface.

Make Tool Cleaning Easier

The quickest way to remove the die is to employ the pressure of the extruder to push it out. Clean the body by using an air compressor and brass pliers so that the material cools down which increases the melt strength, making it into one-lump versus an elastic, gummy-like substance that is harder to remove. Cleaning the body feed port using compressed air and brass pliers to simultaneously cool and remove the excess residue from the feed ports. This procedure is followed by brushing with a round brass brush that polishes the surface. The flow area of the 2" (51 mm) flange adapter should be cleaned by carefully using a brass brush. Examine all surfaces for any irregularities such as burrs and scratches since these must be repaired before the head is reassembled. Most manufacturers recommend using a hand polishing stone to remove the offending burr. Follow stoning with a light application of 600-grit emery cloth if necessary, but avoid rounding edges that are intended to be sharp. Flat sealing surfaces can also be cleaned using a stone, followed by a 600-grit emery cloth. Place the cloth on a clean, flat surface, preferably a surface plate, then apply friction in a circular hand motion until the area is clean and even. The parts in question should all be hardened steel alloys and will not be adversely affected using these methods. Inconel, monel and Hastalloy® are typically not heat-treated, requiring special care and handling to avoid any damage.

Don't Overlook Repairs

Tooling maintenance helps ensure a quality extruded product – one that meets dimensional specifications, maintains the specified minimum tolerance and is economically produced. Dirty, neglected and improperly adjusted tools contribute to excessive compound applications, which in turn complicate maintenance of minimum thickness tolerance. Excess material results in unnecessary costs and these directly affect the profitability of your company and the relationships with your customers.

The Important Final Step – Reassembly

Working from your dedicated tool cart, follow the manufacturer's instructions for reassembly. Give each component a final wipe down with a clean rag before installing. Even the smallest amount of grit, dirt and re-

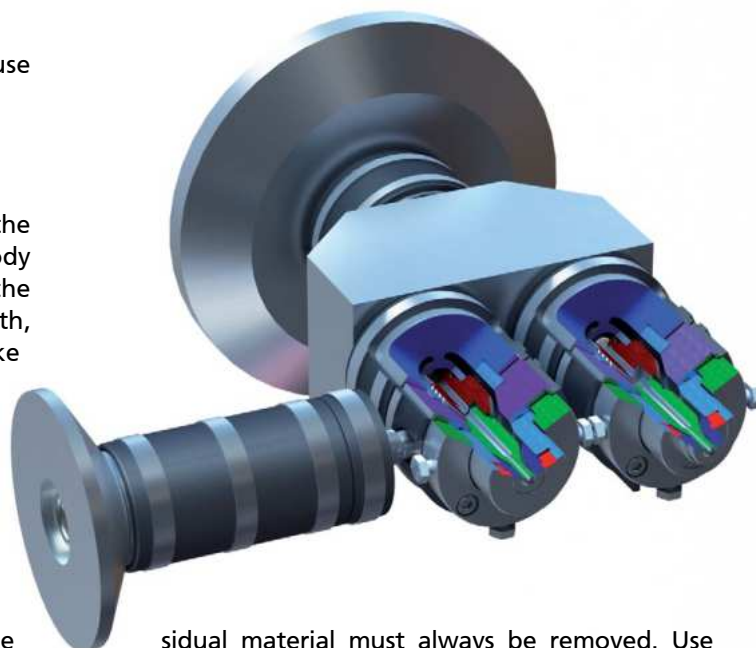

sidual material must always be removed. Use mechanical or manual assistance for heavy and awkward components to avoid unnecessary mishaps. Reapply anti seize compound to all fasteners if required. Tighten fasteners to manufacturer's recommended specifications as well as in the recommended sequence. This fastening sequence should be specified in the manual and is generally in a star pattern. Tighten gradually until the proper torque is achieved to prevent distortion of the tooling. One of a die manufacturer's main goals is to form a concentric cone as quickly and accurately as possible in the primary section of the die – when the extrudate first emerges from the die's distribution capillaries. A properly designed and manufactured die has even distribution close to the extrudate entrance point, but this effort is negated once the die is adjusted, shifting the extrudate off to one side. An eccentric cone is formed in the primary area, and a concentric cone exists at only one point in the process, rather than a smooth, continuous flow path with decreasing volume. A properly manufactured and aligned extruded head, along with well-maintained tooling should require little or no adjustment. Another adverse affect of unnecessary die adjustment is the stress introduced to the extrudate caused by unbalanced flow. The net effect is the final product retains memory of this imbalance and unpredictable die swell occurs.

For a free evaluation and information call, fax or e-mail.

Guill Tool & Engineering Co., Inc.
10 Pike Street, West Warwick, RI 02893
Tel: 401-828-7600 • Fax: 401-823-5310
Email: sales@guill.com
➔ www.Guill.com

Smart Solutions for High Productivity

The German mechanical engineering company Hosokawa Alpine presents practical solutions for system automation and digitalisation that enable customers to operate their blown film lines more efficiently, safely and economically. A digital start-up assistant supports fast and error-free start-up, modern monitoring solutions ensure full transparency during operation and predictive maintenance tools help to avoid unplanned downtimes. This gives customers more planning security, reduces downtimes and increases the overall performance of their production.

Assistance systems make system operation easier

The heart of system automation at Hosokawa Alpine is the ExVis process visualisation software. Among other things, it includes a start-up assistant that makes it easier to start up the system. The settings for a film formulation are stored in the software. This information allows operators to start up the system in four automated steps without having process engineering know-how themselves. The company offers an operating device for the film take-off, which can be connected to the take-off or the collapsing system and operated on site. This gives the operator immediate access to the connected component.

Automation solutions increase efficiency and productivity

Hosokawa Alpine also supports blown film manufacturers with various automation solutions to optimise the use of their systems, speed up processes and measurably increase productivity. This includes an automatically adjustable cooling ring insert. Here, the optimum setting for the cooling air supply can be saved and automatically re-started. The one-touch change included in ExVis includes preset format changes and reproducible settings for the collapsing system and side gussets. The software package thus enables accelerated start-up of a film format and fast switching between different formats. This minimises changeover times and the associated material losses and offers film manufacturers a high degree of flexibility.

Monitoring systems for smooth production

In order to keep the productivity of the systems as high as possible, Hosokawa Alpine provides a system monitoring system that immediately visualises malfunctions in operation and production and enables them to be rectified quickly. A camera system with various cameras on the take-off, winder and MDO pro-



With the modern software solutions from Hosokawa Alpine, film manufacturers can keep an eye on the operating status and productivity of their system at all times

duces images that can then be called up via the operator terminal. This enables an overview from the control panel, even in areas of the system that are not visible. In an emergency, the remote service from Hosokawa Alpine Blueserv, the company's service brand, can quickly access the system.

Predictive maintenance with isa.guard: machine diagnostics in real time

With the predictive maintenance tool isa.guard from Blueserv, maintenance requirements can be precisely

The predictive maintenance tool isa.guard helps to recognise anomalies at an early stage and intervene if necessary



predicted - for maximum system availability and an extended service life. "Problems are recognised before they become critical or even arise. This allows customers to plan interventions proactively and maximise the uptime of their systems," explains Christian Hoffmann, Director Blueserv Blown Film Extrusion. He adds with a wink: "With isa.guard, we have developed a kind of crystal ball that allows us to look into the future."

By analysing a wide range of data and sensors, isa.guard provides a real-time diagnosis of the machine's condition. This gives customers full transparency about their blown film production - around the clock. In addition, concrete proposals for action are provided that enable a targeted and efficient response in good time.

isa.io: information about the machine status - detailed and flexible

The modular software platform isa.io enables a comparative analysis of process data to optimise performance and increase efficiency across all machines. "This gives our customers an excellent overview of all Alpine blown film lines - including the option of carrying out targeted deep dives for detailed analyses. Push notifications and many other functions can also be customised on request," explains Christian Hoffmann.

Hosokawa Alpine Aktiengesellschaft
www.hosokawa-alpine.com

Advanced Calibration Technology for Plastic Pipe Extrusion

As a market-leading provider of adjustable calibration sleeves, CCA provides solutions supporting the automation of plastic pipe production and covering a wide diameter range from 14 up to 2400 mm (inch sizes available).

Combining reliability, in-depth technical knowledge with cutting-edge technology, the calibration sleeve systems from CCA offer an adjustment without maintenance-intensive adjustment gears.

A strong focus on customer requirements drives every stage of development and production, enabling the company to deliver tailored, high-precision solutions for demanding applications.

NEW – Adjustable Calibration Sleeves for PVC Pipe Production

CCA designed this sleeve to enhance efficiency in PVC pipe extrusion.

- Small adjustment range with 2 points in the front area



- Complete sleeve body made of stainless steel
- Durability
- Easy handling
- Proven CCA functional and operational reliability

Adjustable Calibration Sleeves with 4-point Adjustment

Proven CCA quality offering flexibility and reliability for your PE and PP pipe production.

- Four adjustment points allow adjustment of both the diameter and the **ovality**
- Easy handling with high flexibility
- Readable adjustment via numeric counter
- Make larger or smaller adjustments during ongoing production
- Adjustment range for all SDR classes

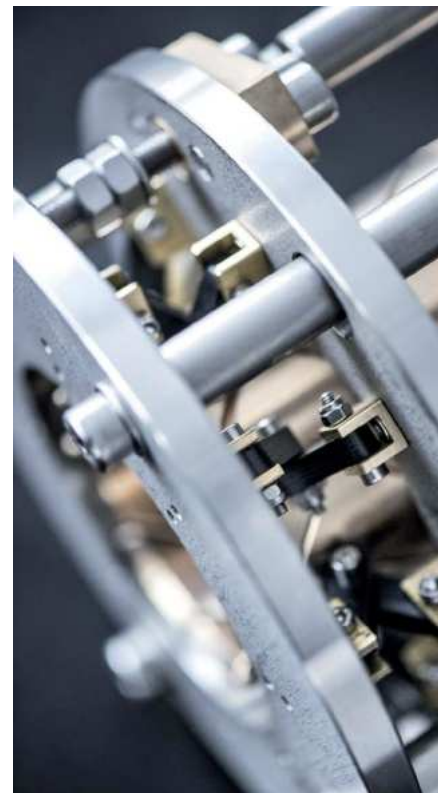

CCA GmbH
 Werkstr. 10, 32584 Löhne, Germany
www.ccagmbh.de

Calibration Sleeves
 Conventional
 Adjustable

More Quality, Less Energy – *Eccentric Pelletizer EGR Optimized*

Coperion has optimized the EGR eccentric pelletizer for use with its two-stage Kombiplast compounding system, improving the system's overall design, air supply, material conveying and pellet handling. In its new design, the EGR delivers significantly better pellet quality, particularly when processing temperature- and shear-sensitive plastics. In addition, Coperion has successfully reduced the pelletizing system's energy consumption.

New smart features also make the redesigned EGR easier to operate compared to the previous model. Heating the pelletizing system and carrying out product changes, including die plate exchange, can now be performed more quickly, increasing the compounder's overall equipment effectiveness (OEE).

The EGR eccentric pelletizer connects seamlessly to Coperion's two-stage Kombiplast compounding system. Coperion has specifically designed both technologies for manufacturing soft PVC, hard PVC, or HFFR formulations.

Higher product quality and lower energy needs

Processing and pelletizing temperature- and shear-sensitive plastics presents significant challenges for the compounding process. The material must be treated as gently as possible throughout the entire process to ensure consistently high pellet quality.

Based upon comprehensive simulations and practical tests, Coperion has optimized the air supply system of the EGR pelletizer. As a result, pellet conveying now takes place under considerably lower feed pressure, resulting in gentler handling of the material. The optimized conveying process not only improves product quality, but also effectively reduces the risk of agglomerate formation.

These enhancements also deliver clear economic and environmental benefits for operators. Compared with the previous model, the new



The redesigned Coperion EGR eccentric pelletizing system achieves higher compound quality and significant energy savings in the manufacture of temperature- and shear-sensitive plastics (Photo: Coperion, Stuttgart Germany)

EGR reduces energy consumption for material conveying by up to 75 percent. In addition to contributing to lower operating costs, the improved efficiency also results in a reduction of the CO₂ footprint.

Increased machine availability

Coperion has also redesigned the die plate heating system so that it can now be easily separated from the die plate. Die plate assembly and disassembly are now significantly faster, an important advantage during recipe changes. At the same time, the pelletizer can be heated up much more quickly, minimizing delays in production.

These enhancements have increased uptime for both the EGR as

well as the entire compounding system, increasing the overall equipment effectiveness (OEE).

Optimized handling

The redesigned EGR pelletizer stands out in particular for its simplified handling. For operating personnel, work safety during die plate changes has been further enhanced. Moreover, a divided, pivoting pelletizer hood provides easier access to the EGR's knife blade, enabling faster, more precise adjustments to the pelletizing knives which in turn improves cut quality. At the same time, the optimized design simplifies both maintenance and service operations, reducing the time required for rou-

tine tasks and helping to minimize downtime.

Another important enhancement is the relocation of the EGR drive to the front of the pelletizer hood. This design change makes it easy to install a screen pack changer between the Kombiplast's discharge and the EGR pelletizer, as is commonly necessary when manufacturing cable compounds.

Kombiplast and EGR: synergy for first-class compounding results

With its two-stage Kombiplast compounder and the EGR eccentric pelletizer, Coperion offers a technology specifically adapted to the manufacture of temperature- and

shear-sensitive plastics such as PVC or cable compounds. The system is designed to ensure particularly gentle product handling throughout the compounding process, while also delivering high economic efficiency and maximum flexibility.

First, the raw materials are fed into the process section of a ZSK twin screw extruder using a twin screw ZS-B side feeder where they are conveyed, plasticized, mixed and homogenized. In its ZSK Mv¹⁴ design with an increased torque of 14 Nm/cm³, the extruder handles the product extremely gently and achieves very high throughput rates. Product discharge takes place via the ES-A single screw that builds up the required pressure for the EGR eccentric pelletizer.

In the pelletizing step the EGR cuts the cylindrical product strands exiting the die plate into uniform pellets using revolving pelletizing knives. The pellets are then removed by pressure conveying, with the help of new inflatable seals installed for this purpose. The pelletizing knives are mounted onto a blade that is eccentrically attached to the die plate. The blade's rotation is infinitely adjustable. Coperion customizes the quantity, diameter and geometry of the die plate holes according to the material properties and individual customer requirements.

Coperion GmbH
Theodorstraße 10, 70469 Stuttgart,
Germany
www.coperion.com

New Dimension in Extrusion Technology

With the successful commissioning of two single-screw extruders with a screw diameter of 360 mm, BB Engineering (Germany) has set a new benchmark: single-screws for processing PET in this size have not been available on the market until now. The systems were recently commissioned at a Chinese customer's site and form the heart of modern BO-PET film lines from Brückner to produce optical films that meet the highest quality requirements.

The newly developed extruders feature a performance-optimized barrier-screw design that enables throughputs of up to 5,400 kg/h. With a screw length of 11.5 m and a diameter of 360 mm, manufacturing and transport posed special technical and logistical challenges that were successfully overcome. The total weight of the extruder is more than 46 t and its length of over 14 m underline the impressive dimensions of this new machine class. Two powerful, energy-efficient, water-cooled motors, each with an output of 700 kW, are used to drive the extruder.

With this extruder size, BB Engineering has achieved a technological milestone in PET processing. The 360 mm extruders open up addi-



tional possibilities for applications in the high-performance segment and underscore the company's strong position in the international market for extrusion technology.

BB Engineering GmbH
Leverkuser Str. 65, 42897 Remscheid,
Germany
www.bbeng.de



Misunderstood Technology – *Why Many PVC Extruders Fail to Unlock the Full Potential of Twin-Screw Extrusion*

Twin-screw extrusion has long been regarded as the reference technology for rigid PVC processing. Its capability to handle heat-sensitive materials with stable fusion and low shear makes it ideal for pipe, profile, window systems, and technical extrusions. Despite this, many PVC manufacturers continue to experience inconsistent quality, excessive scrap, and avoidable downtime – often because the technology is not fully understood or correctly applied.

By: Dariusz Kozłowski

Two issues repeatedly surface in audits and production reviews: limited understanding of how twin-screw extrusion actually generates melt, and the widespread misuse of freeze materials that are incorrectly treated as purge compounds.

Twin-Screw Extrusion Performance: What the Data Typically Shows

When twin-screw extrusion lines are properly configured and operated, processors typically achieve:

- Scrap rates below 2 to 3% on stable production runs
- Melt temperature reductions of 10 to 25°C compared with equivalent single-screw processes
- Torque utilisation in the 65 to 80% range, leaving a stable process window
- Die pressure fluctuations below $\pm 5\%$, supporting consistent surface quality

However, in plants where twin-screw systems are operated using single-screw logic—higher barrel temperatures, aggressive shear input, or poorly matched formulations—performance metrics deteriorate significantly. Scrap rates of 6 to 10%, unstable melt temperatures, and frequent start-up rejects are commonly observed, eroding both margins and capacity.

The key issue is not the machine, but how its fundamentals are applied.

Twin-Screw Plasticisation: Compression, Not Shear

Counter-rotating twin-screw extruders plastify PVC primarily through controlled compression and residence time, rather than extreme shear. This allows full fusion at relatively low melt temperatures, preserving thermal stability and surface quality.



When operators compensate for poor fusion by increasing temperature rather than addressing mechanical plasticisation, the result is a narrower processing window and higher degradation risk—especially during speed changes or brief stoppages. Over time, this leads to plate-out, colour instability, and premature wear of screws and dies.

Freeze Compounds: A Protective Tool, Not a Purge Material

Freeze materials are not designed to clean. Their function is to protect PVC remaining in the extruder during standstill. When hot PVC stops flowing, degradation accelerates rapidly. Freeze compounds stabilise the mate-

rial by limiting molecular mobility and thermal reaction during downtime.

Correctly applied freeze strategies typically deliver:

- 30 to 50% reduction in black-speck incidents after shutdowns
- Shorter restart scrap lengths
- Lower incidence of corrosive degradation residues

By contrast, incorrect dynamic use of freeze material often results in higher material consumption with little or no improvement in cleanliness or restart quality.

The Hidden Cost of Incorrect Practice

Misunderstanding twin-screw fundamentals and misusing freeze compounds leads to measurable losses, including:

- Extended start-up waste of 20 to 40 minutes per changeover
- Increased compound consumption with no performance benefit
- Chronic surface defects misattributed to raw materials
- Higher maintenance and polishing frequency for screws and dies

These losses are rarely captured on a single KPI but accumulate across shifts, products, and weeks of production.

A Low-Cost Opportunity for Performance Improvement

Importantly, none of these issues require new capital investment. Plants that focus on process understanding typically achieve:



- Downtime reductions of 10 to 20%
- Scrap reductions of 2 to 5 percentage points
- Improved output consistency with lower thermal stress

In today's cost-pressured environment, these gains represent a significant competitive advantage.

Conclusion

Twin-screw extrusion delivers its true value through understanding, not assumption. Treating it as a high-output "black box" and misapplying tools such as freeze compounds undermines performance, quality, and profitability.

- Manufacturers who revisit basic processing principles and use freeze materials correctly can unlock measurable improvements in efficiency, stability, and long-term asset life – without changing a single piece of equipment.

Author:

Dariusz Kozlowski is a PVC extrusion professional with hands on experience across technical, production, and leadership roles. He has worked as a Technician at Centaur Manufacturing, Production Leader within Rediplex Group, and Head of Extrusion at RAM Extrusion. His focus is on twin screw process optimisation, operational stability, and reducing scrap and downtime in rigid PVC extrusion.

RAM Extrusion
Unit 203 Pointon Way, Stonebridge Cross,
Droitwich, Worcestershire WR9 0LW, UK
Dariusz@ramextrusion.co.uk
► <https://ramextrusion.co.uk/>

Building on a Legend

Eighteen months after his appointment as CEO at Vetaphone A/S, Michael Behrens spoke with Nick Coombes about his role and responsibility to build on the foundation laid by the Eisby family in pioneering surface treatment technology.

Nick Coombes: You became CEO of Vetaphone in late 2024. What was your first impression of the role?

Michael Behrens: From day one, I knew I was stepping into more than just a job title. It was clear that this role is about stewardship as much as leadership. Vetaphone is a family-owned company built on engineering excellence and a strong sense of responsibility to the industry, and that heritage sets a clear direction for how the company should be led.

NC: You are the first non-family CEO. How does that influence your leadership approach?

MB: Continuity is essential. I am the first non-family CEO, but Frank and Jan Eisby remain actively involved through the Management Board. My role is therefore not to reinvent the company, but to build on its strengths by adding structure, scale, and momentum while preserving Vetaphone's unique DNA.

NC: What stood out to you when you joined the company?

MB: What impressed me most was the pride and professionalism across the organisation. From engineering and production to sales and support, there is a shared focus on delivering the right solution for the customer rather than simply shipping equipment. Surface treatment is evolving fast – higher running speeds, more data, more consistency and less downtime. We must be able to respond to these changes. It's important that we continue to listen carefully to our customers so that we can provide premium products and service in what is an ever-increasingly competitive marketplace.

NC: How do you define your main responsibility as CEO?

MB: My responsibility is to ensure that Vetaphone continues to perform and grow as a truly global

business. Today we serve customers in more than 75 countries, supported by around 100 employees across seven countries. Equally important is our global agent network, which plays a critical role in our success by providing strong local presence, application expertise, and long-term customer relationships, all backed by Vetaphone's core know-how.

NC: How does Vetaphone stay ahead in such a competitive and fast-moving market?

MB: We stay ahead by delivering far more than a corona treatment unit. Our role is to provide the know-how that ensures customers get the right solution the first time, based on their specific application and production requirements. We build on more than 75 years of experience by continuously improving our technology – smarter electronics, better energy efficiency, and systems that are safer and easier to operate. Equally important is our ability to support customers locally, with service and support available 24/7/365. This enables predictive maintenance and continuous optimisation, so our customers' production always runs reliably and efficiently.

NC: Knowledge sharing seems to be a recurring theme. Why is that important?

MB: Knowledge sharing is integral to our role as the original inventor of corona treatment technology. Vetaphone pioneered the corona technology that is used worldwide today, and that position carries both authority and responsibility. Over decades, we have built unmatched application and process knowledge, and we consider it our obligation to define best practice and share that expertise with our customers – so they achieve stable production, consistent quality, and long-term operational performance.



Michael Behrens is the first non Eisby-family CEO of Vetaphone

NC: How are you preparing Vetaphone for future growth?

MB: We invest continuously in tools, processes, and people to ensure we can scale in a controlled and predictable way. At the same time, ESG and sustainability remain priorities, and we use Ecovadis as a structured framework to measure and improve our performance.

NC: What does long-term success look like for Vetaphone under your leadership?

MB: For me, it's about building a company that can scale without losing its character - that can continue to lead the way in surface treatment and build a business that is ready for the future, not just the next order. My goal is to keep Vetaphone the most reliable name in surface treatment for our customers, our partners, and those who work here. We have the heritage, the technology and the people. The future is not about changing what we are, it's about becoming even more of what makes us special. I'm proud to lead Vetaphone into its next chapter, and even prouder of the team that makes this possible every day.

#3-2026

RECYCLING

Regular Section
in EXTRUSION INTERNATIONAL Magazine



Retrofit Solutions for Recycling as Virgin Material Prices Increase

After a phase of comparatively low prices, the market for virgin plastics has shifted significantly. Driven by geopolitical developments, price levels are rising continuously, directly impacting material costs for processors.

As a result, previously stable cost structures are coming under pressure. At the same time, recyclates are gaining renewed relevance – both as an economic alternative and in response to regulatory requirements. Under the EU Packaging Directive, mandatory minimum recycled content targets must be met by 2030.

However, a large share of installed production lines is not designed for higher recyclate input – particularly from post-consumer streams. In addition, increasing recyclate usage typically comes with higher variability in material quality.

Retrofitting existing lines to handle increased recyclate volumes is, in many cases, less complex than assumed. Gneuss provides retrofit solutions that enable existing extrusion lines to process both virgin material and recyclates in a stable and



controlled manner – without requiring complete system replacement.

Gneuss Retrofit Concepts

Gneuss retrofit concepts focus on the targeted optimization of extrusion and melt filtration. Combining these process steps enables a Super-Clean recycling approach, producing high-quality polymer melts even from contaminated post-consumer material – reaching virgin-like quality levels in many applications, including food contact.

The extrusion system is based on a specifically engineered screw design that not only ensures efficient melting and homogenization, but also supports intensive degassing and melt decontamination. This allows stable processing of materials with elevated moisture content, volatile contaminants, or low bulk density.

Melt filtration based on Gneuss Rotary technology ensures continu-

OMNI recycling system for processing up to 100% post-consumer material – combining preparation, degassing and filtration

ous, process-stable removal of solid contaminants. The fully automatic system operates without process interruption, even under fluctuating input conditions and high recyclate shares.

Extrusion and filtration systems can be implemented either as stand-alone upgrades or as an integrated solution. System configuration is tailored to specific objectives – such as increasing recyclate throughput, stabilizing product quality, or enabling food-contact compliance.

Due to their compact design, integration into existing lines typically requires minimal modification of the surrounding infrastructure.

Summary

Increasing recyclate usage is both an economic necessity and a regulatory requirement. The key challenge lies in ensuring consistent product quality despite fluctuating input materials.

Gneuss addresses this with tailored retrofit concepts based on a Super-Clean recycling process – enabling reliable processing and high-quality output, up to and including food-contact applications.

Functional principle of the self-cleaning, process-constant Rotary filtration system RSFgenius



European Expertise for High-Quality Plastics Recycling

The use of recycled plastics in high-quality end products is gaining importance worldwide – driven by sustainability targets set by international brand owners and regulatory requirements. At Chinaplas (21 to 24 April 2026, Shanghai), EREMA showed how proven recycling technology can deliver consistently high-quality regranulates for a wide range of applications. EREMA focused on recycling solutions for high-quality end applications.

PET recycling: flexibility for different target markets

Solutions for PET continue to account for the majority of recycling systems in China. EREMA has already installed more than 50 VACUREMA® and VACUNITE® systems in the region. The trend is moving towards food-grade applications. "Our technologies offer customers maximum flexibility," explains Christoph Wöss, Global Sales Director at EREMA. "The regranulates are used in applications such as sheets, fibers, or packaging. As soon as the market opens up for bottle-to-bottle recycling, our customers can immediately enter this segment as well."

One area with great potential is tray-to-tray recycling (take-away packaging). The required technology has already been proven on an industrial scale. Danish company Faerch, a leading food packaging manufacturer, is considered a pioneer in this field with its recycling division Cirrec: trays made from rPET thermoforming film contain up to 100 per cent recycled post-consumer PET and meet stringent requirements in terms of food safety, durability and transparency.

The VACUREMA® and VACUNITE® machine series have been approved by globally recognized food safety authorities for the production of food-grade rPET. In December 2025, EREMA also received four additional positive opinions from the European Food Safety Authority (EFSA) in accordance with EU Regulation 2022/1616. This confirms that the technology meets current requirements for decontamination and process validation. Furthermore, the distinction between bottle and sheet applications reduces complexity for recycling companies.

"The majority of rPET in China is currently used in textile production," adds James Qiu, General Manager at EREMA Shanghai. "With a future opening of bottle-to-bottle recycling, it will be crucial to establish solutions that keep PET within its respective loops." With the PET fibre-to-fibre technology FibrePro:IV, as well as the investment announced in October in Australian cleantech pioneer BlockTexx®, EREMA is consistently expanding its expertise in textile recycling.

Post-consumer recycling gaining momentum

"We are seeing growing interest in post-consumer solutions in China," says James Qiu. "EREMA supports cus-



EREMA experts at Chinaplas: Once again in 2026, the team in Shanghai will be available for in-depth discussions on high-quality plastic recycling (Photo Credits: EREMA GmbH)

tomers with extensive expertise." For example, together with Irish company Polymer Matters and joint venture partner Lindner Washtech, a recycling process has been realised in which HDPE milk bottles from post-consumer collections are recycled and used again to produce new milk bottles. The combination of washing and extrusion technology forms the basis for the high quality of the recyclate. The process was recently classified by the European Commission as an advanced novel technology for direct food contact.

Increasing requirements can also be observed in the recycling of film waste. Household, supermarket, and agricultural films pose particular challenges due to contamination and moisture. With the INTAREMA® TVEplus® DuaFil® Compact, EREMA offers a solution designed for such demanding material streams.

While post-consumer regranulates are already being used in high-quality products in Europe, there are still only a few applications in China. One pioneering example is INTOCO. The company operates around 30 INTAREMA® TVEplus® systems equipped with EREMA laser filters for EPS recycling. James Qiu explains: "The regranulates achieve a high level of quality and are used in premium products such as picture and photo frames. Thanks to its integrated value chain, INTOCO holds a strong international market position."

Close to the customer

EREMA has been present in Asia for decades and has operated its own subsidiary in China since 2005. The locally based technicians have received comprehensive training at the company's headquarters in Austria and provide on-site support to customers. Additional subsidiaries in Asia are located in India and Thailand.

Turning Waste into Raw Materials – Recycling Diapers Instead of Burning Them

The founding team at LaMa Recycling is carrying out an innovative research project at the SKZ Plastics Center to recycle previously unusable production waste from diaper manufacturing. Instead of being incinerated, cellulose, plastics, and superabsorbents can be separated, processed, and returned to the raw material cycle—a step that conserves resources and reduces CO₂ emissions.

The founding team of LaMa Recycling—Dr. Marieluise Lang, Dr. Lars Helmlinger, and Thomas Wolz – is developing a novel recycling process to recover valuable raw materials from production waste generated during plastic processing. The goal of the research project is to develop an industrially viable process that returns previously non-recyclable production residues back into the raw material cycle.

The focus includes, among other things, polyolefin blends and plastic chips from industrial manufacturing, which have so far been entirely incinerated. As a result, the materials they contain are irretrievably lost and further burden the carbon footprint. The new technology is designed to process this waste and make the contained raw materials available again – an important contribution to resource conservation and the reduction of emissions. A particular focus is on production waste from diaper manufacturing.

“Around six billion diapers for children and adults are produced in Germany each year. About three percent of these, roughly 15,000 tons, are production waste that has previously been entirely incinerated,” explains Dr. Marieluise Lang. “This results in the loss of valuable raw materials, while at the same time, thermal recycling significantly impacts the carbon footprint.



The LaMa Recycling project team is conducting an innovative research project at SKZ to develop a novel recycling process as part of the “EXIST Research Transfer” funding program. (From left): Stefan Zuljevic, Dr. Lars Helmlinger, Dr. Marieluise Lang, and Thomas Wolz (Photo: SKZ)

Superabsorbents as a Recycling Obstacle

A major obstacle to the recycling of diaper production waste is so-called superabsorbents—highly absorbent polymers that enable diapers to absorb liquids. Their chemical properties have made recycling them costly or economically unviable until now.

Scalable Recycling Process

Since September 2025, the interdisciplinary team at LaMa Recycling Technologies has been working at full strength. In the current project phase, the work focuses on the technical scaling of the process. The goal is to establish a stable and scalable

recycling process with a processing capacity of at least 500 kilograms per hour by the end of the project – an important step toward the industrial application of the technology.

The project is being implemented at SKZ, as the institute draws on many years of experience in plastics research and provides state-of-the-art laboratories for the development of innovative recycling technologies. SKZ is also supporting the spin-off of LaMa Recycling and assisting the team in translating research results into practical applications.

The SKZ Plastics Center
Stefan Zuljevic

► s.zuljevic@skz.de, www.skz.de

Food Contact Approval for Recycled Films Obtained

UBE Corporation Europe announced that a UBECycle® certified mechanically recycled polyethylene/polyamide (PE/PA) grade^[i] has successfully obtained Food Contact approval, enabling UBE to expand its offering into application areas where regulatory compliance and material reliability are essential.

This achievement represents the latest milestone in an ongoing development strategy aligned with Circular Economy objectives. In line with the development of new products that contribute to circularity, UBE has continued with the scale-up and commercialization of the UBECycle® product line, a polymer range designed to enable the transformation of industrial PE/PA or polyamide film waste into high-quality recycled materials through controlled mechanical recycling.

Food Contact suitability guaranteed through independent testing

The food-contact suitability of this UBECycle® material is ensured through specific analysis performed by an accredited entity, including migration and compliance testing.

At EU level, food-contact compliance for plastic materials is governed by European regulations. The applicable regulatory requirements for this UBECycle® grade are fully addressed and documented, confirming its suitability for food-contact applications under defined conditions of use.

From recycling expertise to certified and regulated solutions

The food-contact approval achieved today builds on a structured and progressive journey undertaken by UBE over recent years. This journey began with the integration of Paulowsky^[ii]'s recycling know-how and capabilities, which strengthened UBE's expertise in the mechanical recycling of PE/PA and polyamide-based materials.

Building on this foundation, UBE focused on certifying its recycling processes, ensuring traceability, process control, and consistent material quality. As a result, the UBECycle® product line achieved RecyClass^[iii] certification in accordance with EN 15343:2007^[iv]. The audited recycling process and associated management systems meet the requirements of the Recycling Process Audit Scheme, with procedures in place to ensure the traceability and verification of recycled plastics throughout the value chain.

Creating new opportunities

The Food Contact approval opens new opportunities in sectors requiring strict regulatory compliance and premium materials quality, leveraging UBE's established experience in the existing markets such as food packaging industries, as well as other high-performance applications.

UBE will continue to expand its UBECycle® portfolio and support customers in navigating regulatory frameworks, certification schemes, and technical requirements for recycled applications.

[i] Food Contact approval applies only to specific UBECycle® material grades and is subject to individual homologation. Food-contact suitability must be assessed and confirmed on a grade-by-grade basis according to applicable regulations and conditions of use.

[ii] Paulowsky (Manufacturas Paulowsky S.L.U.) is a Spanish Recycled Plastics located in Valencia (Spain), which was acquired by UBE Corporation Europe S.A.U.. In December 2024, Paulowsky and UBE entered into a share transfer agreement, under which UBE received majority shares in Paulowsky. The release: <https://ube.es/acquisition-of-recycled-plastics-manufacturer-by-ubes-subsi-dary-in-europe/>

[iii] RecyClass is a European certification initiative providing third-party verification of recycling processes and traceability of recycled plastics in accordance with recognized standards such as EN 15343. <https://recyclclass.eu/>

[iv] Paulowsky, S. L. U. has Recycling Process Certification, which demonstrates the traceability and responsible management of recycled plastics. The scheme is aligned with both EN 15343:2007 and ISO 22095:2020 controlled blending model standards. For more information: <https://recyclclass.eu/certifications/recycling-process/>

Next-Generation AI Platform Launched and GAINnext™ Ecosystem Expanded

TOMRA Recycling has unveiled a breakthrough AI-native platform from PolyPerception and introduced three new deep learning applications for its award-winning GAINnext™ technology. The innovations were presented at IFAT 2026 in Munich and PRSE in Amsterdam, highlighting the company's continued focus on advancing AI driven sorting solutions. The announcement coincides with TOMRA increasing its investment in PolyPerception to a 51% majority stake, closing the loop between real-time stream data and physical sorting action.

From reporting to interpreting: An AI agent for recycling

PolyPerception's new AI-agent platform marks an impressive evolution of its Waste Analyzer – an AI-powered waste analytics solution that improves sort-

Data is interpreted, explained and transformed into relevant insights in a few seconds



TOMRA Recycling unveils a breakthrough AI-native platform from PolyPerception for real-time data analysis

ing performance through end-to-end material tracking. One of the most significant breakthroughs is the natural language interface. Operators can now 'chat' with their plant data in plain language, asking questions such as "How did changing the settings on the recovery line affect our purity?". With AI as its core, the platform understands the context and provides immediate natural language answers accompanied by data breakdowns, removing the technical barrier between complex spreadsheets and operational decision-making.

While traditional AI tools in the industry are limited to 'reading' and reporting data, this platform also has 'writing' capabilities, enabling it to act like an agent within the plant. Rather than just observing material streams, it can actively create custom quality reports and set operational alerts in seconds based on its deep domain knowledge of the recycling process.

"With the introduction of our new agent-based platform, recycling plants now gain a new cognitive layer," says Nicolas Braem, CEO and Co-Founder of PolyPerception. "Data is no longer just reported – it is interpreted, explained and transformed into relevant insights in a few seconds. Operators can interact naturally with their plant, ask questions, explore material behavior and receive clear, actionable answers in real time."

Open data and advanced search features

This groundbreaking technology provides full transparency by allowing recyclers to integrate plant data di-



GAINnext™ achieves 95% purity in PET tray sorting, turning a technical challenge into a viable business case

rectly into their existing management systems. This enables managers to query waste statistics or purity levels through their own dashboards without needing to log into a separate system.

The platform also introduces two powerful new search methods to help plants respond to changing material streams:

- **Similarity search:** Operators can right-click a problematic object, such as an electronic vape, to instantly identify every other visually similar item in the stream. This is critical for spotting fire hazards like batteries without the need to train a new AI model.
- **Text and brand search:** Users can search for specific brands or object types, such as 'filled refuse bags' or 'diapers', to see exactly what is passing through the facility in real time.

"AI has always been part of TOMRA's DNA, but we are now entering an entirely new phase," says Lars Enge, EVP and Head of TOMRA Recycling. "With our acquisition of a majority stake in PolyPerception, we are moving beyond AI as a sorting tool to AI as a central intelligence for the recycling plant. By combining our advanced sorting systems and digital solutions with PolyPerception's AI platform we are creating an end-to-end solution that doesn't just optimize machines but fundamentally redefines how plants operate."

Expanding the GAINnext™ ecosystem

To complement this technological progress, TOMRA is also introducing three new deep learning applications for its GAINnext™ ecosystem. This solution targets long-standing industry bottlenecks where traditional sensor-based sorting has reached its limits.

The first application addresses the rising demand for food-grade PET trays as tray material is becoming a critical new feedstock alongside bottles. By training GAINnext™ on thousands of images, the system can now distinguish between takeaway or super-market trays and consumer or medical packaging based on shape and use. This breakthrough achieves purity levels over 95%, demonstrating that PET tray



TOMRA introduces three new deep learning applications for its GAINnext™ ecosystem to boost sorting precision

sorting is no longer a technical challenge but a viable business case.

In the metals sector, TOMRA is launching a high-precision application for 'copper meatballs', supporting a steel market that is starting its journey towards decarbonization. The new GAINnext™ automatically identifies complex copper-steel composites, such as motor armatures, even in oxidized or dirty streams, delivering outstanding selectivity and helping recyclers to upgrade rebar-grade scrap to premium furnace feedstock.

The third addition is a high-throughput solution for used beverage can (UBC) aluminum recovery from packaging streams – an application that was successfully launched in North America and has now been adapted for the European market. The GAINnext™ UBC application offers up to 33 times more throughput than manual sorting, delivering 98% purity or higher. By instantly detecting and ejecting non-UBC materials, the system provides a more efficient, automated path for aluminum can-to-can recycling.

Technology turning point

"These launches signal a true technology turning point for the industry," Enge concludes. "Deep learning is no longer just enhancing individual processes or tackling increasingly complex sorting challenges – it is linking insights directly to action across the plant. We are moving beyond high-speed detection toward a new era of intelligent, connected sorting, where complex challenges are solved and data is understood, contextualized and communicated directly to the operator. Once again, TOMRA is at the forefront of innovation, translating today's most advanced AI into real, measurable value for customers."

Successful 2025 Results – Over 37,000 Tonnes of Agricultural Plastics Recycled

The ERDE initiative (Erntekunststoffe Recycling Deutschland) continues its successful growth trajectory. In 2025, a total of 37,342 tonnes of agricultural plastics were collected and sent for material recycling within the take-back and recycling system established by RIGK and its partners.

Despite an overall reduction in market volumes, the initiative further increased its recycling input rate compared to the previous year, making the system even more efficient. ERDE has once again made a significant contribution to the circular economy in agriculture.

Recycling these materials resulted in savings of approximately 37,042 tonnes of CO₂ equivalents. This corresponds to around 350 million kilometres driven by passenger cars, the annual mileage of approximately 28,400 vehicles, or the carbon sequestration capacity of around 2.7 million trees.

“The results demonstrate that our system works in practice when all stakeholders pull together,” says Boris Emmel, System Manager of the ERDE initiative. “The high level of participation from agricultural businesses, trade and collection points shows that circular economy principles are increasingly being implemented in agriculture. Every returned agricultural plastic helps to keep valuable raw materials in circulation and sustainably reduce environmental impact.”

Shared responsibility across the value chain

The results of the ERDE collection campaign are the outcome of collaboration between numerous stakeholders. Under the umbrella of the IK Industrievereinigung Kunststoffverpackungen, manufacturers work together with RIGK GmbH as system operator, agricultural businesses, collection partners, recyclers and the agricultural trade to ensure a functioning take-back and recycling system.

The basis for this is the initiative’s voluntary commitment to the German Federal Ministry for the Environment. It defines concrete targets for the collection and recycling of agricultural plastics – including a collection rate of over 60% for asparagus films by 2026 and 75% for silage and stretch films by 2027.

Dr Laura C. Müller, Economic Affairs Advisor at IK Industrievereinigung Kunststoffverpackungen, emphasises: “The continuous progress shows that voluntary industry solutions can work in the spirit of the circular economy. ERDE is an example of how producer responsibility can be implemented in practice together with agriculture, trade and the recycling industry.”



Successful commitment to environmental and climate protection – turning used agricultural plastics into new resources (© RIGK / ERDE)

Expansion of the take-back system – infrastructure and material streams growing

Alongside stable collection volumes, the initiative’s network continues to expand. With more than 700 collection points and over 160 collection partners, ERDE now provides a comprehensive infrastructure for the return of used agricultural plastics.

The collection portfolio is also continuously being expanded. Following successful pilot projects, greenhouse films and drip irrigation pipes have now been permanently integrated into the system. In addition, further manufacturers are joining the initiative, strengthening both the financing and ongoing development of the system.

Strengthening the circular (agricultural) economy and European exchange

ERDE aims to continue its successful path in the coming years. The goal remains to further increase collection volumes and continuously expand the network across the agricultural value chain.

At the same time, the initiative is increasingly engaged in international dialogue on take-back and recycling systems for agricultural plastics. Exchange with industry stakeholders and national initiatives across Europe is intended to help share best practices and further advance the circular economy in the agricultural sector.

Initiative ERDE

➔ www.erde-recycling.de

Producing High-Quality Regranulate Efficiently

Rising requirements for recyclates used in sensitive applications are accelerating the further development of advanced plastics recycling solutions. At Plastics Recycling Show Europe in Amsterdam, recycling machinery manufacturer and systems provider EREMA demonstrated how advanced technologies and coordinated process chains enable the production of high-quality regranulates for demanding end use applications.

Against the backdrop of regulatory requirements such as the EU Packaging and Packaging Waste Regulation (PPWR), recycling technologies that focus on degassing performance, odour optimisation and process stability are gaining importance in Europe. Recyclates are required for sensitive applications, both for food and cosmetic grades as well as for other premium quality levels. At PRSE 2026, EREMA demonstrated how these requirements can be implemented in industrial operations.

VOLEX further developed: more options with increased degassing performance

With its VOLEX technology, EREMA set a new benchmark for degassing post consumer streams at K 2025. Based on experience gained since market introduction, the technology has since been further developed under practical operating conditions. Targeted optimisation of the screw geometry enables degassing performance levels that previously required a larger machine size. The latest technology update allows VOLEX to be used both with and without water stripping, with the optional water injection opening up additional potential for sensitive applications.

“Decontamination and deodorisation effects that, compared with standard systems on the market, can only be achieved through several hours of thermal post treatment of the pellets can already be realised directly during the extrusion process thanks to VOLEX. This reduces energy consumption and operating costs for recycling companies,” explains Markus Huber Lindinger, Managing Director at EREMA. “The strong increase in melt surface area, combined with TVEplus® technology, results in an optimal balance between degassing performance and thermomechanical stress on the input material,” he continues.

Together with customers and partners, EREMA is working to optimise the process specifically for defined application areas. Of particular relevance are applications with high quality requirements where odour plays a role, but which do not require food or cosmetic grade standards. These include, for example, components for automotive interiors such as cable ducts, or packaging for household chemicals, such as bottles for household cleaners. The latter are expected to gain importance in view of the EU Packaging Regulation, emphasises Clemens Kitberger, Business Development Manager at the EREMA Group: “Many companies have so far only addressed the question of which products will fall under the PPWR requirements in the future to a limited extent. At EREMA, we are prepared to economically provide the high degassing performance required for applications in the medium sensitive range.”

Food grade polyolefins: next level achieved in the Novel Technology process

Alongside technological development, EREMA, together with joint venture partner Lindner Washtech and Irish recycling company Polymer Matters, presented significant progress in food grade recycling of polyole-



With EREMA's VOLEX technology, high levels of decontamination and deodorisation can be achieved directly during the extrusion process. For many medium sensitive applications, this eliminates the need for additional thermal post treatment of the pellets



The joint project by EREMA, Lindner Washtech and Polymer Matters, focusing on the recycling of HDPE milk bottles, has reached the next stage in the European Commission's Novel Technology approval process. From right to left: Clemens Kitzberger (EREMA Group) and Michael Cunningham (Polymer Matters) (Photos Credits: EREMA GmbH)

fins at PRSE. In the European Commission's Novel Technology authorisation process, the joint project – which returns PCR from HDPE milk bottles to the same loop – has reached the next stage.

"In order to produce food grade rHDPE in Europe, the recycling process must be authorised in accordance with EU Regulation 2022/1616. Achieving Advanced Novel

Technology status marks an important milestone and demonstrates that mechanical recycling can also enable food grade recyclates for polyolefins economically and on an industrial scale," says Kitzberger. "Importantly, this is not a closed loop system, but input material from mixed household collections."

A deep understanding of the entire process chain – from the selection and preparation of the input material through to extrusion and decontamination – is crucial for such progress. A specialised food grade team of market experts and experienced chemists translates the respective requirements into suitable concepts. Validated challenge tests as well as internal and external laboratory analyses form the basis for robust material assessments. Experience gained from numerous projects also feeds into the structured support of authorisation procedures, where reproducible results and clear documentation are essential prerequisites.

High regranulate quality through coordinated processes

High-quality regranulate and consistent process efficiency in post-consumer recycling require that every stage of the entire plant is coordinated from the outset. This is precisely where the close collaboration between EREMA and Lindner Washtech comes into play: material preparation, washing and extrusion are designed not as individual process stages, but as a seamless, integrated process.

Developments cover several key aspects, ranging from process stability and energy efficiency to system connectivity. A central lever is data exchange across the entire process chain. Using a jointly developed HMI, relevant process data from material preparation, washing line, extruder and downstream process steps are consolidated in a structured overview. This transparency enables targeted process optimisation and throughput oriented plant design.

EREMA Group

► www.erima-group.com

EXTRUSION GLOBAL

**THE SPECIALIZED WEBPORTAL
ON EXTRUSION
FOR EVERY MODERN NEED**



VM Verlag GmbH
Cologne, Germany



www.extrusion-global.com

The new SAVEOMAT P+

MADE IN GERMANY

Designed for PVC Dry Blends

The new SAVEOMAT P+ is the perfect weigher for the dosing of PVC Dry Blends. Since Dry Blend formulations can differ in the type and number of additives and filler material, the weighing hopper must be suitable to ensure a steady flow and dosing of the material, independent of the flowability. For this reason, the P+ hopper is available in two different versions:

- » **Without integrated agitator:**
For good to medium flowable PVC Dry Blends, containing up to 25 PHR CaCO₃
- » **With an integrated agitator:**
For high filler PVC Dry Blends, which show a poor flowability

Advantages and features:

- Modular design
- Dustproof without the need for filter cloths
- Retrofit-ready: The agitator can be added later if the material properties change
- A perfect fit for SAVEOMAT PVC dosing systems just like for mono component applications
- All proven iNOEX control options available for constant production, product quality and material savings

More details here:



iNOEX
INSPIRE BEYOND MEASUREMENT

